

 **RELIABLE**



5500SD

**Automatic Thread Trimmer Single
Needle Lockstitch Sewing Machine
w/ Direct Drive**



In this manual, you'll find instructions on how to use and prepare your machine.

To watch the videos for 5500SD, please visit www.youtube.com/@ReliableCorporation for a complete video playlist.



Contents

1.	Attention before operation	5
2.	Caution in using	5
3.	Lubrication	6
4.	Adjusting oil flow for the rotating hook	6
5.	Mounting the needle	7
6.	Loading the bobbin	7
7.	Threading the needle	8
8.	Winding the bobbin thread	9
9.	Lifting of presser foot	9
10.	Built-in LED light	10
11.	Operating the treadle	10
12.	Adjusting the presser foot pressure	11
13.	Adjusting the tension of stitch thread	11
14.	Adjusting the take-up spring	12
15.	Adjusting the height of the needle bar	13
16.	Reverse Stitching and Index Stitching	13
17.	Programming	14-20
18.	Parts Book	21-44

1. Attention Before Operation

1. Before you put the machine into operation for the first time after the set-up, clean it thoroughly.
2. Though every machine is strictly inspected and tested before leaving Reliable, the machine parts may be loose or after long distance transportation due to jolt. A thorough examination must be performed after cleaning the machine. Turn the balance wheel to see if there loose, uneven resistance or abnormal noise. If these exist, adjustment must be made accordingly before the machine is operated.
3. Never operate the machine without lubricating the oil pan.
4. Confirm the power plug has been properly connected to the power supply.
5. The rotation of the sewing machine is counterclockwise as observed from the hand-wheel side.

2. Caution

1. To avoid personal injury, never put your hand under the needle when you turn "ON" the power switch or operate the machine.
2. To avoid personal injury, never put your fingers into the thread take-up cover while the machine is in operation.
3. To avoid possible accidents because of abrupt start of machine, turn OFF the power of the machine before tilting the sewing machine head.
4. Always turn OFF the power when leaving the machine.
5. To avoid personal injury, never operate the machine with any of the safety devices removed.
6. Never clean the surface of the machine head with paint thinner or similar chemical.

3. Lubrication

1. Fill oil pan (1) with machine oil up to HIGH mark (A).
2. When the oil level drops below the LOW mark (B), refill the oil pan with the specified oil.
3. When you operate the machine after lubrication, you will see splashing oil through the sight window (2).

Caution: When you first operate your machine after setup, please ensure that you see the oil splashing through the window. Please note that it may take a minute or so for the oil to work its way up from bottom.

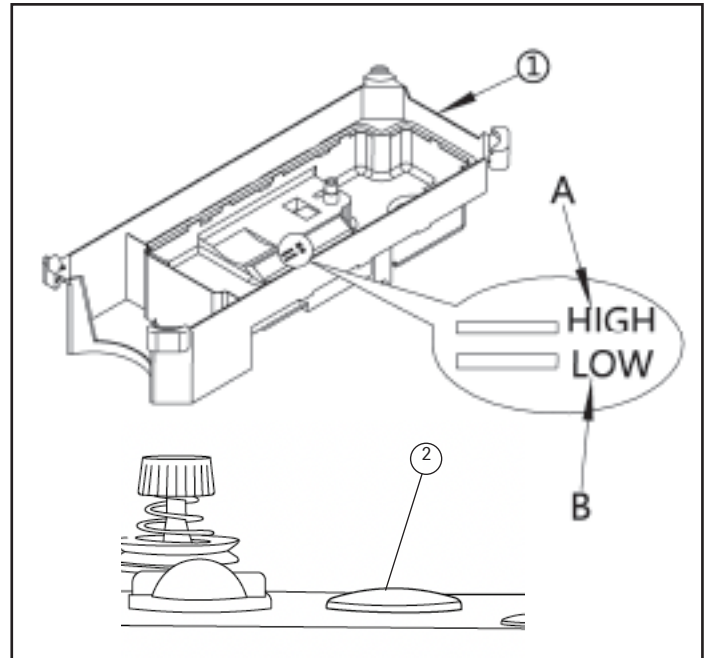

4. Adjusting Oil Flow for the Rotating -

1. Turning the screw clockwise will increase the amount of oil going into the rotating hook. Turning the screw counterclockwise will decrease the amount of oil going into the hook.
2. Check the lubrication amount again after adjusting the flow of the oil to see if the rotating hook has been properly set.

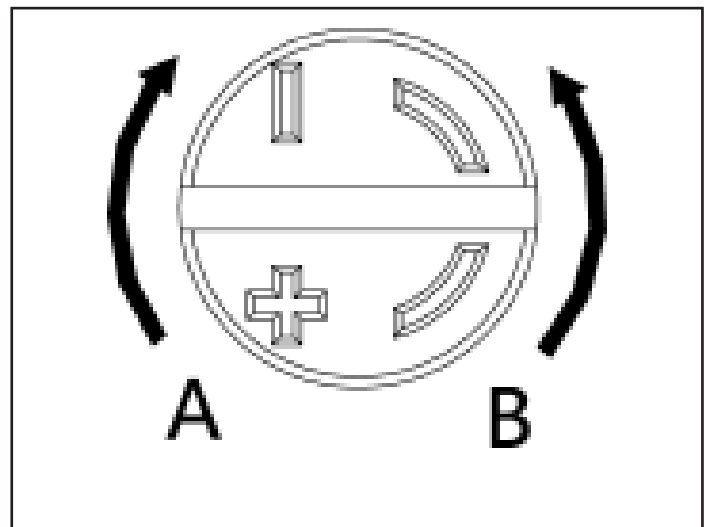

5. Mounting the Needle

1. Turn the hand wheel counterclockwise until the needle stops at its maximum height.
2. Loosen needle screw (2) using a screwdriver provided with the machine.
3. Insert the needle (1) into the bottom of needle bar in direction of arrow till it reaches the end point.
4. Ensure that the cut out or scarf (A) is to the right and the long groove (C) to the left.
5. Tighten the needle screw (2).

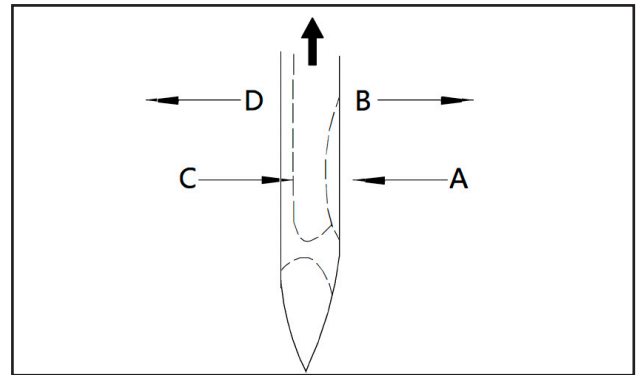
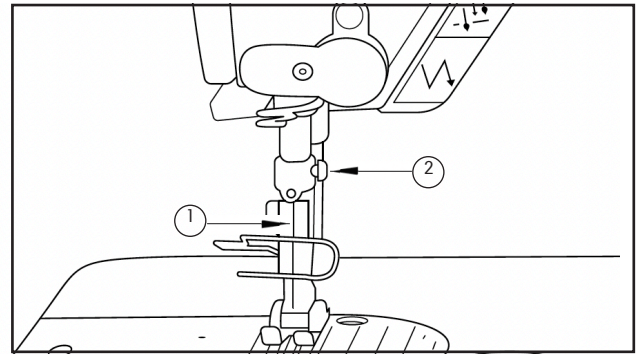

6. Loading the Bobbin

1. Load the bobbin into the bobbin case.
2. Feed the thread through slot A of the bobbin case then securing the thread under the tension spring C. In this way, the thread is led out of hole B through the tension spring.
3. When bobbin thread is drawn, the bobbin will turn clockwise in direction of arrow.

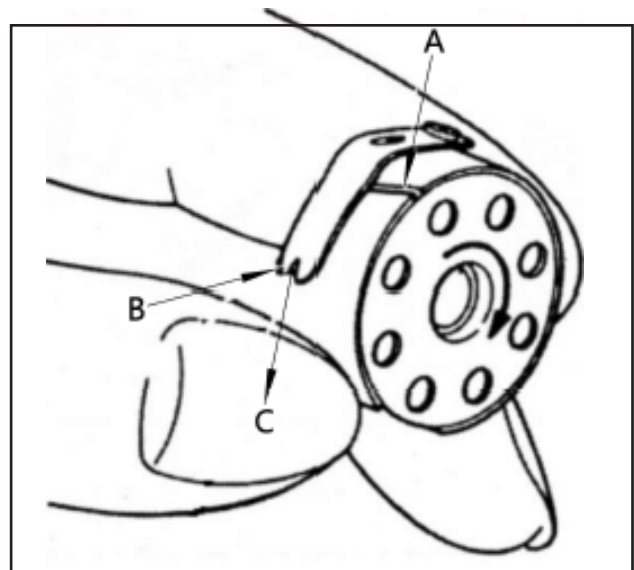

7. Threading the Needle

Raise the needle bar so it stays at its highest position and lead the thread from the thread stand in the order as shown in the figure.

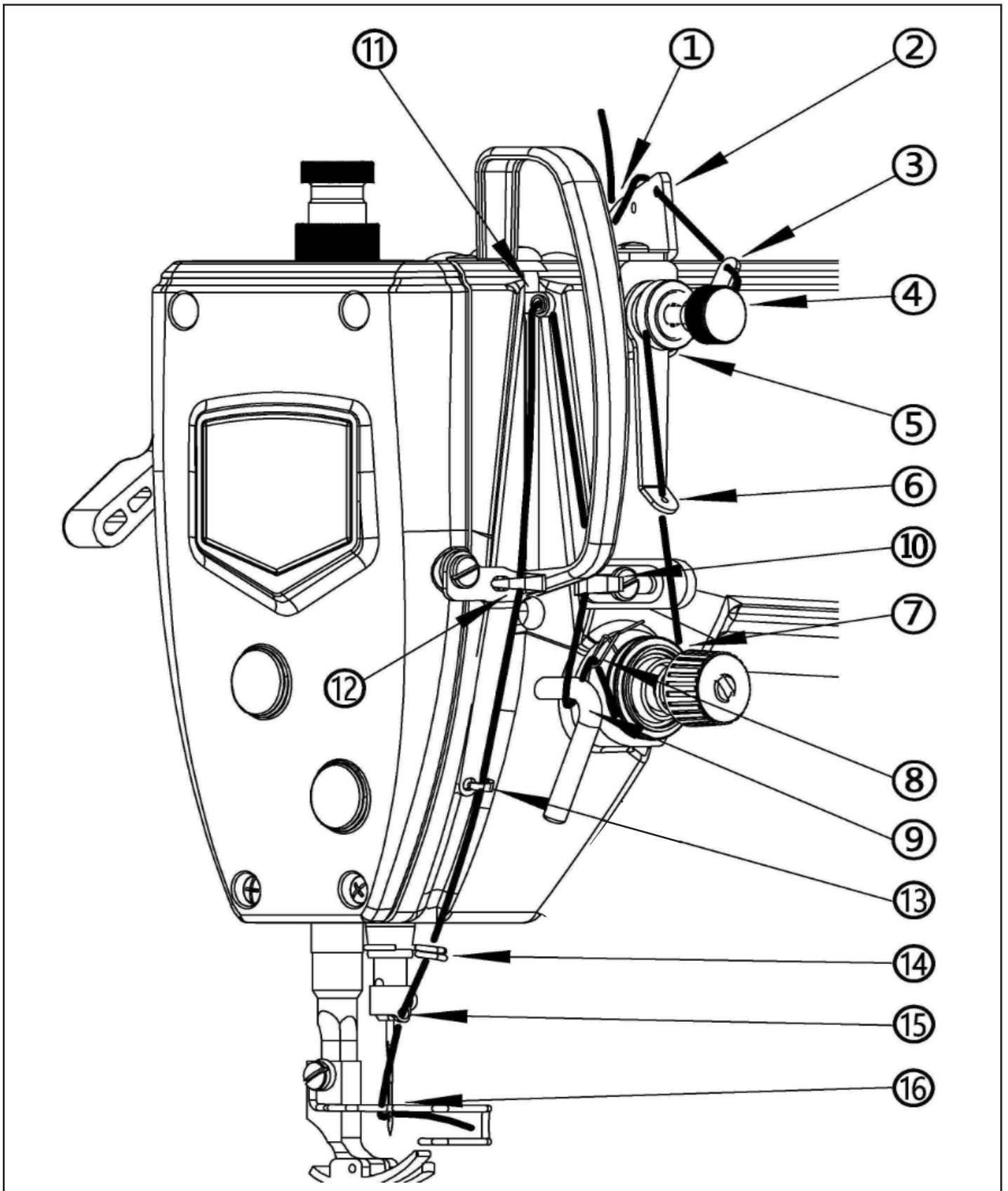

8. Winding the Bobbin

Bobbin thread winding-up method

1. Insert bobbin (1) onto the bobbin winder post (2).
2. Feed the thread through the tension assembly. Wind the thread onto the bobbin clockwise for several turns.
3. Push winding lever (3) into the bobbin. The bobbin (1) is rotated in direction C and thread is reeled onto bobbin (1). Once the bobbin is full, winding lever (3) is pushed towards direction B and winding is over.
4. Remove bobbin (1) and trim off the thread using thread trimmer (4).

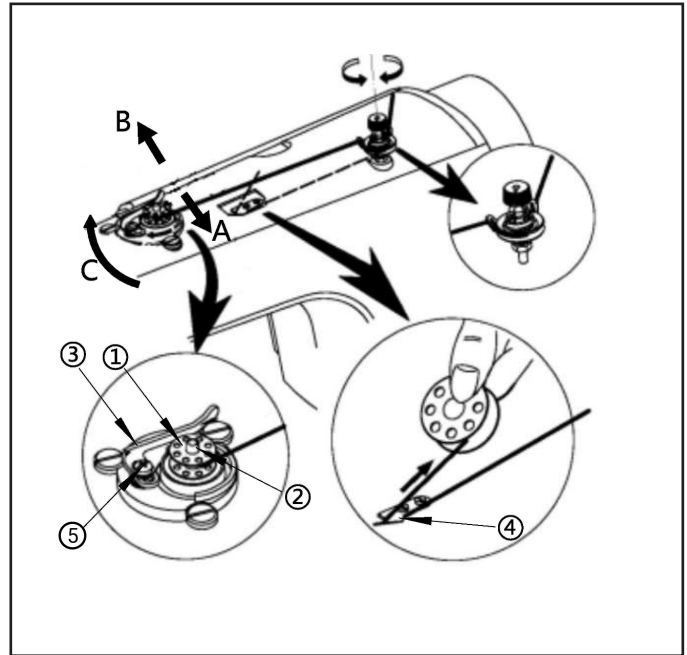

9. Lifting of Presser Foot

- 1) Lift presser foot controlled by hands
1. Turn presser foot lever (1) in direction A to lift the presser foot.
 2. When presser foot lever (1) is turned in direction B, presser foot will be returned to its original position.

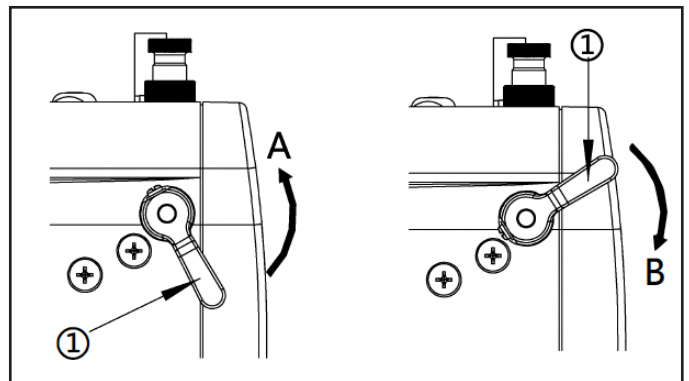

2) Lift presser foot controlled by knees or

1. Press knee lever (2) to lift the presser foot (for about 13 mm).
2. Heel back on the pedal will also lift the presser foot electronically.

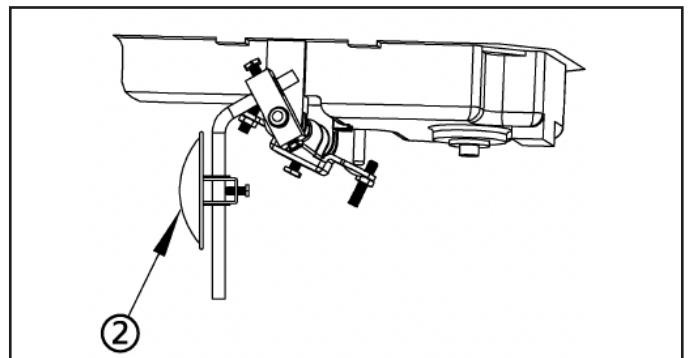

10. Built-in LED Light

The sewing machine comes with a built-in LED light. The light has three illumination settings.

When the machine is powered on, the LED light is turned on at level three, which is the brightest setting.

Press the light button (1) in sequence to reduce the brightness until it switches off.

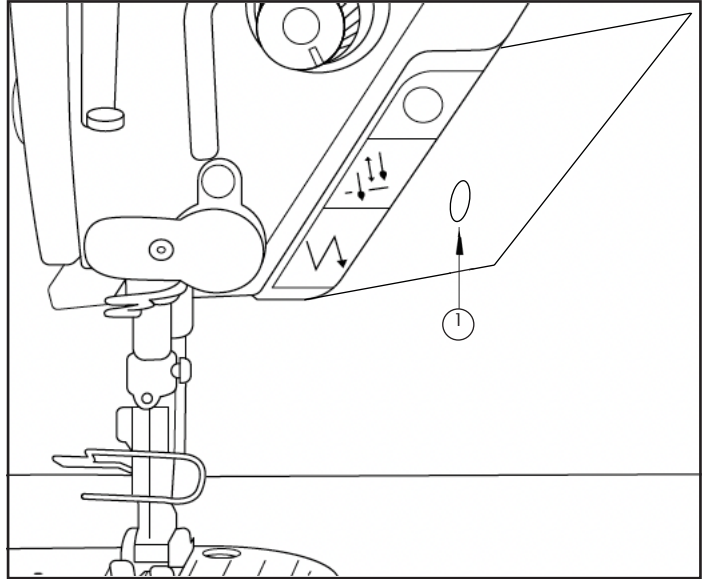

11. Operating the Treadle

The treadle has 4 operation levels:

1. The machine runs at low sewing speed when you partially press the front part of the pedal (A).
2. The machine runs at high sewing speed when you fully press the front part of the pedal (B).
3. The machine stops working when you pedal back to home position. Then, when you partially press the back part of the pedal, the foot will lift (C).
4. The machine lifts the foot and trims the threads, when you fully press the back part of the pedal (D).

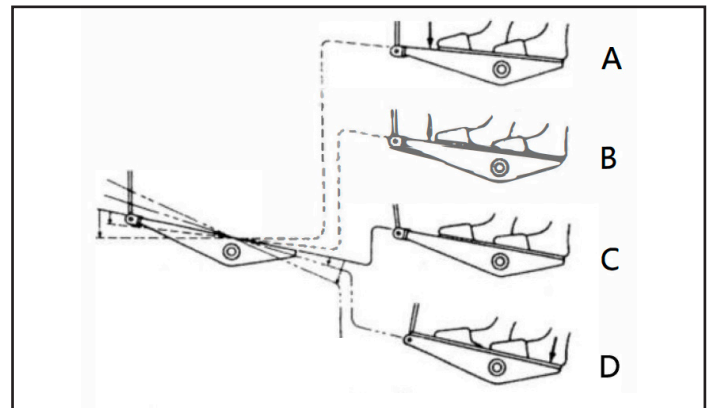

12. Adjusting the Presser Foot Pressure

1. Loosen locking nut (2).
2. Turn (1) screw in clockwise direction (A) to increase the pressure on the foot.
3. Turn (1) screw in counterclockwise direction (B) to decrease the pressure on the foot.

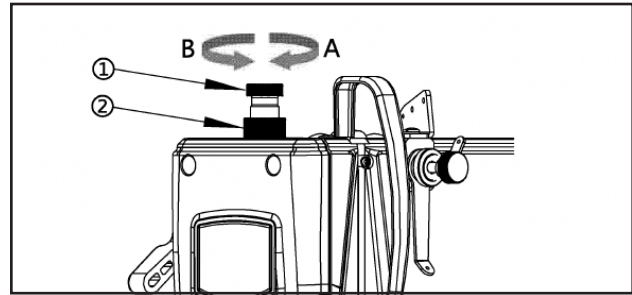

13. Adjusting the Tension of Stitch Thread

- 1) Adjusting the tension of bobbin thread
 1. Hold the bobbin case and use the adjusting large rotating screw (1) to regulate.
 2. Turn the screw in clockwise direction (A) to increase the tension. Turn (1) screw in counterclockwise direction (B) to decrease the tension.

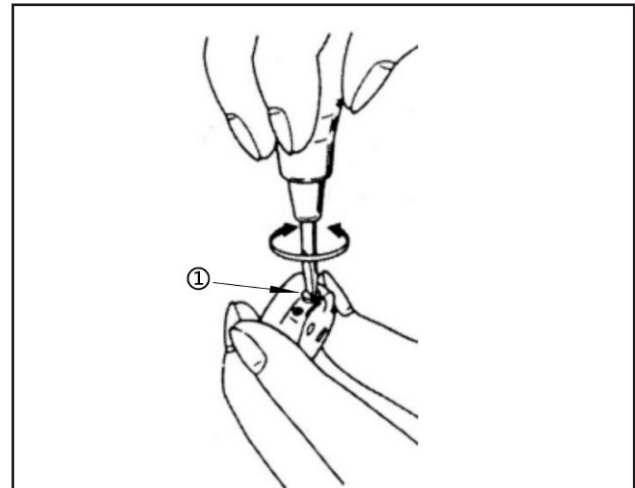

2) Adjusting the tension of needle thread

After the lower thread tension is adjusted, adjust the upper thread tension so that a good, even stitch is obtained.

1. Lower the presser foot.
2. Adjust by turning the tension nut (2): to increase the tension of the upper thread, turn the nut clockwise (A). To decrease the tension of the upper thread, turn the nut counterclockwise (B).

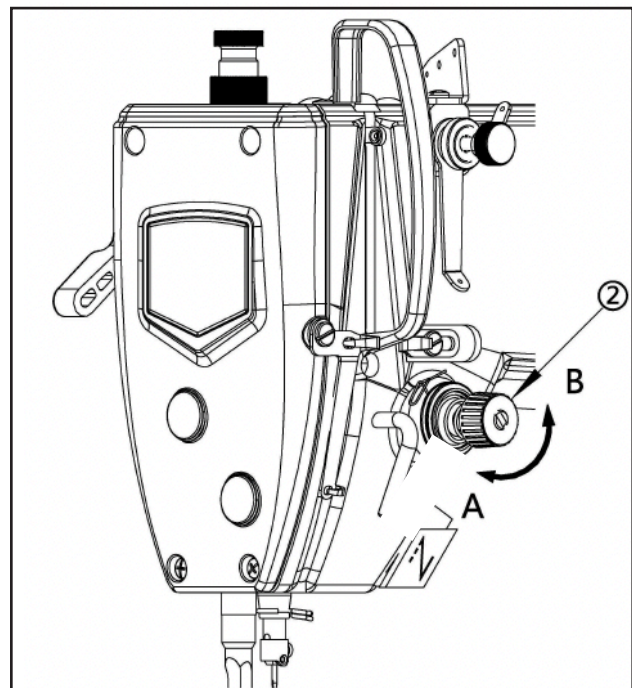

14. Adjusting the Take-up Spring

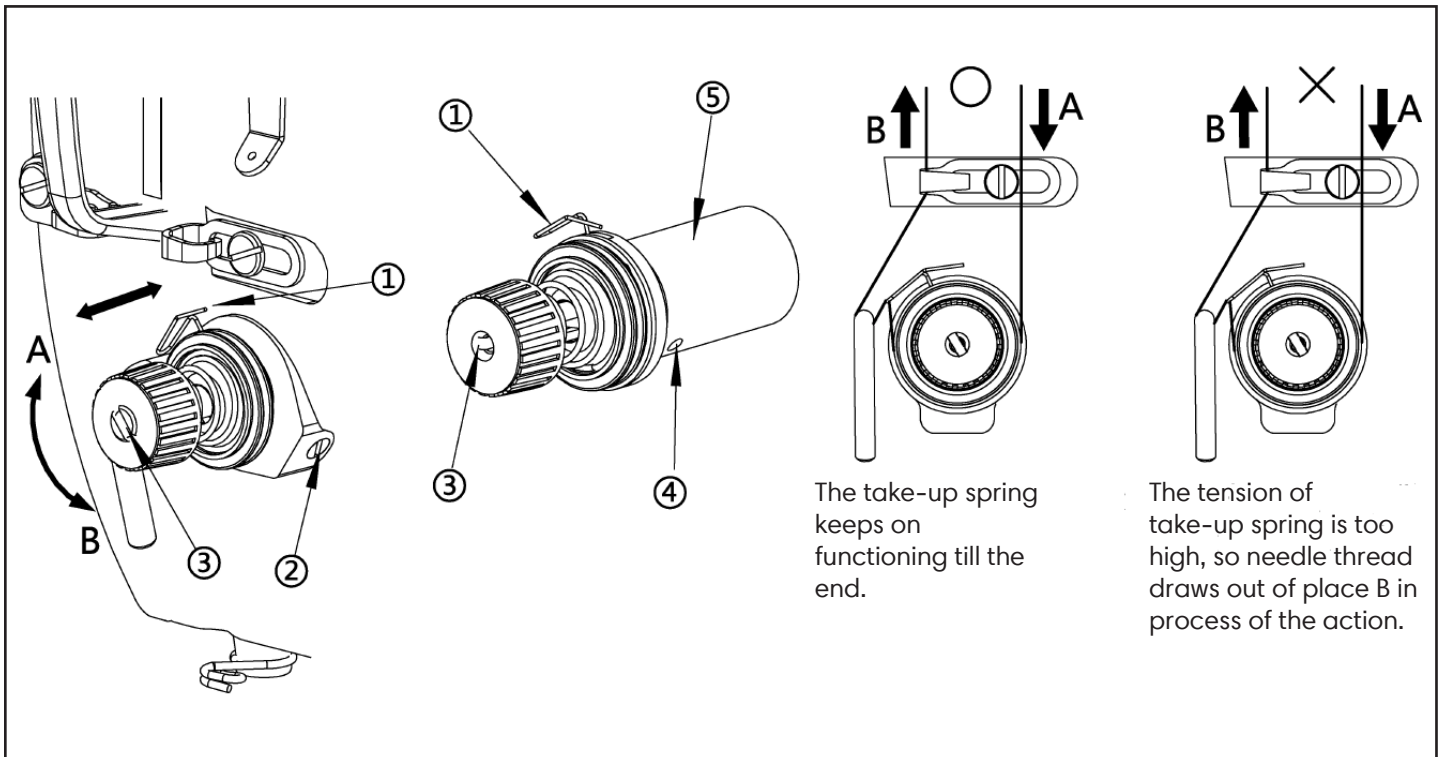

1. Loosen screw (2) and remove the check-spring assembly (5).
2. Loosen screw (4) to adjust the check-spring.
3. Rotate the post (3) clockwise to increase the check-spring tension. Rotate the post (3) counter-clockwise to decrease it.
4. Tighten screw (4) to lock in the check-spring tension.

15. Adjusting the Height of the Needle Bar

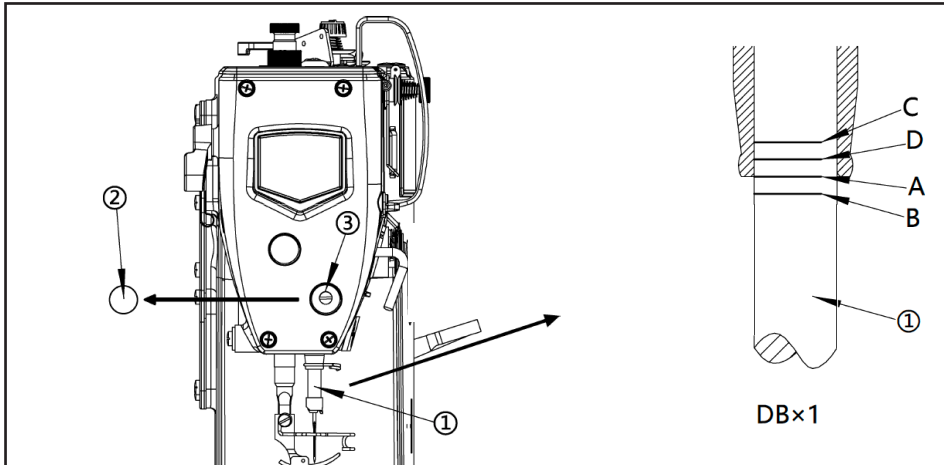

1. Turn the machine hand wheel to set the needle bar (1) to its lowest position.
2. Remove the rubber cap (2) from the face plate.
3. Loosen the needle bar locking screw (3) of needle bar, through moving the needle bar (1) up and down to adjust, when using needle DBx1, the mark A on the needle bar (1) should match to the bottom of needle bar lower bushing.
4. Tighten the needle bar locking screw (3) after adjusting.

16. Reverse Stitching and Index Stitching

- Press the reverse button (1) to activate reverse sewing.
- Press the half stitch/index stitch button (2) to activate a half stitch. Hold for continuous sewing.
- Press the condensed half stitch/index stitch button (3) to activate a condensed half stitch. Hold for continuous sewing.

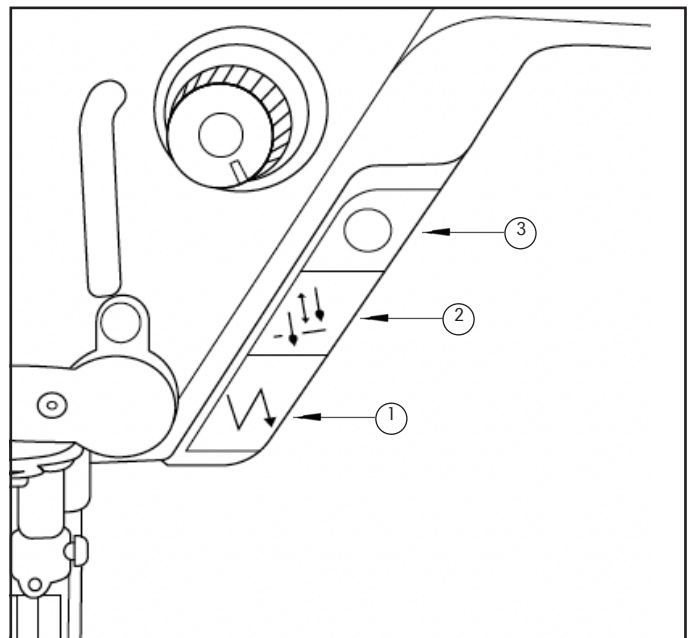

Programming 5500SD

Safety Precautions

Please read the operation manual and related sewing machine datasheet carefully for correct use.

1. Power voltage and frequency: please refer to motor and control box nameplate.
2. Interference from electromagnetic wave: please keep far away strong magnetic or high radiation environment in order to avoid obstructions and make to misoperation.
3. Grounding: to avoid the noise obstructions or leakage of electricity accident (including sewing machine, motor, control box and positioner).
4. Please make sure power is off for at least 1 min and then open control box cover because of dangerous high voltage.
5. Please turn off the power while repairing or wearing needle in order to protect operator's safety.



6. Used where potential dangers exist.





Used where high voltage and electric danger exist.

7. Product warranty period of one year on condition that this machine is operated correctly and no man-made damage



Basic Operation

Adjusting the Sewing Speed

Press the left  or the right  arrow to decrease or increase the speed respectively. Once complete, wait for 2 seconds and your setting will automatically save.

Note: The maximum speed is 5000 RPM. The recommended speed setting is 2800 RPM.

Adjusting the Stitch Length

Press the  or the  key to increase or decrease the stitch length respectively. Then, press  to set.

Note: The stitch length can be set between 0-5mm.

Setting the Needle Positioner

Press and hold  until the needle icon is visible on the screen.



Needle Up









Needle Down

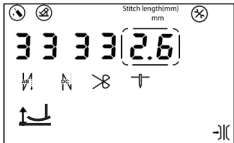

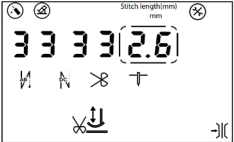

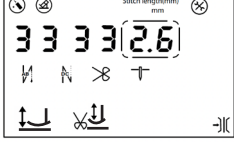

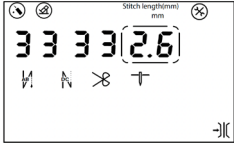
Setting the Thread Trimmer Function

Press  to engage and disengage the Thread Trimmer.

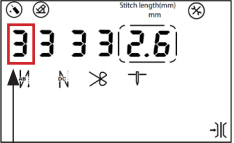
Setting the Presser Foot Lift

1.	Press  to engage the presser foot lift, when you stop sewing. Once selected, the presser foot lift key would be visible on the programmable panel.	
2.	Press the  key again to engage the presser foot lift after thread cutting. This will engage once you heel back to engage the thread cutter.	
3.	Press the  key a third time to engage the presser foot when stop sewing and after thread cutting.	
4.	Press the  key to turn off the presser foot lift function.	

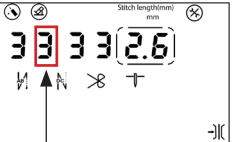
Setting the Back Tack/ Secure Stitch Length

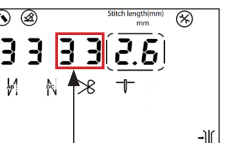
1.	Press the  button to enter the back tack stitch set screen.	 <p>Position 1</p>
2.	Press the  key. The first number will light up. Then, press the  or  key to increase or decrease the number of stitches in the back tack from 1-9. When finished press the  key, moving to the next number.	 <p>Position 2</p>
3.	Repeat the process with all the 4 numbers. Then, press  to save. Position 1 & 2 are for the number of stitches to back tack/ secure stitch when you begin sewing. Position 3 & 4 are for the number of stitches to back tack/ secure stitch when you finish sewing and heel back.	 <p>Position 3 and 4</p>

Back Tack Stitching

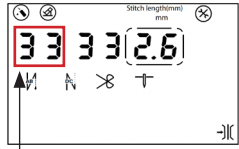
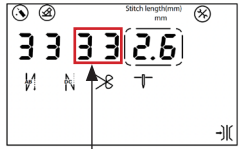
1.	<p>Start Back Tack/Secure Stitch</p> <ul style="list-style-type: none">• Push once for position 1 one, segment(A). For example, if position 1 is set to 3, the machine will back tack 3 stitches when starting to sew.• Push twice for two back tacks, position 1 and 2, segment (A then B). For example, if position 1 is set to 3 and position 2 is set to 2, the machine will back tack 3 stitches than forward 2 stitches. It will repeat this once.• Push a third time, the machine will back time the same as twice, but it will repeat two times.	 <p>Position 1 and 2</p>
2.	<p>Finish Back Tack/Secure Stitch</p> <ul style="list-style-type: none">• Push once for position 3 one, segment(C). For example, if position 3 is set to 3, the machine will back tack 3 stitches when finishing stitching.• Push twice for two back tacks, position 3 and 4, segment (C then D). For example, if position 3 is set to 3 and position 4 is set to 2, the machine will back tack 3 stitches than forward 2 stitches. It will repeat this once.• Push a third time, the machine will back time the same as twice, but it will repeat two times.	 <p>Position 3 and 4</p>







Setting the Voice Mode

1. Press **(P)** for 4 seconds until the screen reads 0000.
2. Enter the code 7141, then press **(S)**.
3. Scroll up or down with **(< >)** to Parameter 90, then press **(S)**.
4. Use the **(+)** or **(-)** to move up or down through the options.
 - 0 - Cancels the voice mode.
 - 1 - Voice mode set to Chinese.
 - 2 - Voice mode set to English.
5. Press **(S)** to save.

Reset

If at any time you need to reset to factory settings, press and hold **(Reset)**.

Advanced Operations

Fixed seam pattern key		After this function is enabled, the front and rear fixed seams can be sewn according to the self-editing pattern
Trigger function key Settings		1. Effective (on/off) in fixed-length seam mode (one-section seam, multi-section seam, multi-section seam self-knitting pattern) 2. W seam mode Open automatically
Motor Angle adjustment/trial teaching function		1. Debug mode shortcut key in free seam mode (long press for more than 3 seconds) 2. In fixed-length seam mode, try teaching mode (press for longer than 1 second)
Thread clamp function		Thread clamp function on and off. Electronic tension is enabled after open it
Anti-nest function		Anti-nest function on and off, is suitable for the machine with Anti-nest equipment
Three - segment mode switching		Short press to switch one-stitch sewing/multi-stitch sewing/free sewing/circulation:w sewing Free seam
Slow start function		Slow start on and off

Error Codes

Error Code	Contents	Possible reasons	Checking and treatment
E011 E012	Motor signal error	Motor position sensor signal failure	If electric engine plug is well contacted; if electric engine signal detecting device has been broken; if sewing machine handwheel correctly installed.
E021 E023	Motor overload	motor stall motor overload	If electric engine plug is well contacted; if machine head or thread-cutting mechanism has been blocked completely; f materials are too thick; Electrical signal detection signal whether the normal.
E101	Hardware drivers fault	Current detection abnormal Driving hardware error	Current detection loop system is working properly; Whether the damage to the device driver.
E111 E112	Voltage too high	High input voltage Brake circuit fault Voltage detection error	System into line voltage is too high; Braking resistance are working properly; System voltage detection circuit are working properly.
E121 E122	Voltage too low	Actual low voltage Voltage detection is wrong	If the voltage on the inlet wire is too low Whether the system voltage detection circuit the normal work.
E131	Current circuit fault	Current detection abnormal	Current detection loop system is working properly.
E133	Oz circuit fault	Oz circuit fault	Oz circuit system is working properly.
E134	DBFLT malfunction	Automatic resistance circuit failure	Brake resistor plug is in good contact Brake resistance is damaged
E201	over current	Current detection error	Current detection loop system is working properly Electrical signal is normal.
E211 E212	Abnormal motor operation	Current or voltage detection error	If electric engine plug is well contacted If electric engine signal
E301	Communication error	Sci circuit error	if operation box plug is well contacted; if operation box components are damaged.
E302	Operation inner failure	Sci circuit error	check whether the operating box is damaged.
E303	SPI Communication breakdown	Sci circuit error	check whether the main control board is damaged.
E304	HMI From the main chip communication failure	Sci circuit error	check whether the operating box is damaged.
E402	Pedal ID fault	Pedal verification fault	Pedal connection is loosen.
E403	Pedal zero position fault	The pedal zero position over range	The pedal is damaged or it is not under stop state when correction
E501	Safety switch fault	Safety switch effective	Put down the head or check turned up switch.
E502	Fuel fault alarm	Fuel fault alarm	Add oil Tips
E601	Hardware drivers fault	Feed motor STEP2 hardware overcurrent	Current detection loop system is working properly; Whether the damage to the device driver.
E602	Hardware drivers fault	Feed motor STEP2 software overcurrent	Current detection loop system is working properly; Whether the damage to the device driver
E603	Hardware drivers fault	Feed motor STEP2 Current detection circuit	Current detection loop system is working properly; Whether the damage to the device driver.
E604	Motor signal error	Feed motor STEP2 The initial mechanical angle	Feed motor connector is a good contact
E605	Motor signal error	Feed motor STEP2 at the start, Encoder or rotor stuck	Feed motor connector is a good contact Machinery is stuck
E606	Hardware drivers fault	Feed motor STEP2 Motor winding circuit	Current detection loop system is working properly; Whether the damage to the device driver.
E607	Hardware drivers fault	Presser foot trimming motor STEP1 hardware overcurrent	Current detection loop system is working properly; Whether the damage to the device driver.

E608	Hardware drivers fault	Presser foot trimming motor STEP1 software overcurrent	Current detection loop system is working properly;Whether the damage to the device driver.
E609	Hardware drivers fault	Presser foot trimming motor STEP1 Current detection circuit	Current detection loop system is working properly;Whether the damage to the device driver.
E610	Motor signal error	Presser foot trimming motor STEP1 The initial mechanical angle	Presser foot trimming motor connector is a good contact
E611	Motor signal error	Presser foot trimming motor STEP1 at the start,Encoder or rotor stuck	Presser foot trimming motor connector is a good contact Machinery is stuck
E612	Hardware drivers fault	Presser foot trimming motor STEP1 Motor winding circuit	Current detection loop system is working properly;Whether the damage to the device driver.
E613	Hardware drivers fault	The feed motor STEP2 is running ,Encoder or rotor stuck	Feed motor connector is a good contact Current detection loop system is working properly;Whether the damage to the device driver.
E614	Hardware drivers fault	The Presser foot trimming motor STEP is running ,Encoder or rotor stuck	Feed motor connector is a good contact Current detection loop system is working properly;Whether the damage to the device driver.
P.oFF	Power off Display	Power off	Wait for power supply to resume.
EvAL	Trial expired	Trial expired	Contact the dealer processing
L.bob	The bottom line tips	The bottom line count value is negative	After replacing the bottom line, press P to cancel the Alert Status
P.bob	Remind of counting by piece	The number of counting is 0	Press S key to enter the interface, and long press "front seam" button for more than 2 seconds to cancel the prompt state

System Parameter Table

	Project	Content	Setting range	step pitch	The default value	Level
P-01	Sewing speed	Set sewing speed	200~5000(rpm)	100	3700	I
P-02	Soft-start function	1~9: Soft start stitches	0~9	1	2	I
P-03	Decorative tacking sewing setting(effective for only presser foot or thread trimming)	Can realize perfect decorative tacking sewing stitch function 0: Invalid 1: Valid	0/1	1	0	I
P-04	Fixed-length seam sewing speed	Set fixed-length seam sewing speed	200~4000(rpm)	100	3000	I
P-05	Easy sewing mode setting	Easy mode setting 0: Invalid 1: Valid	0/1	1	0	I
P-06	Zero pitch correction value	When the needle pitch is set to 0mm, fine the value so that the actual sewing needle pitch is zero	50~150	1	100	I
P-07	Positive needle distance correction value	Magnification positive sewing distance (Sewing needle fixed distance)	50~150(%)	1	100	I
P-08	Anti-needle distance correction value	Enlarge reverse stitches Distance Scale (Sewing needle fixed distance)	50~150(%)	1	100	I
P-09	Back stitch speed limitation	can keep needle from breaking while backstitching	500~1500(rpm)	50	800	I
P-10	Set the length of the stitch from the set number	0:Set the number of stitches to set the value 1:When the length is set to self-made, the number is the number of the pattern, that is, the total number of stitches is the number of stitches × set the value	0/1	1	1	I
P-12	Height of middle presser foot lifting (valid stepping)	Setting height of presser foot lifting when sewing half	0~100	1	60	II
P-13	Maximum height of presser foot lifting (valid stepping)	Setting Maximum height of presser foot lifting after trimming	0~100	1	50	II
P-14	Speed of presser foot lifting (valid stepping)	Stepping speed of presser foot lifting	20~300(rpm)	10	150	II
P-15	Speed of presser foot releasing (valid stepping)	Stepping speed of presser foot releasing	20~300(rpm)	10	150	II
P-16	Output duty cycle of presser foot soft drop	Output duty cycle of presser foot soft drop	0~100	1	20	II
P-17	Cut and loosen duty cycle	Cutting line for electromagnet; When the shear line loose line duty ratio (too small will affect the shear line electromagnet suction strength) Cutting line for step: Loose line efforts to adjust the (light)	0~100	1	50	II
P-18	Front reinforcing-sewing setting after the front fixed joint is connected	Immediately after the end of front reinforcing-sewing, step on the cutting line without the function setting of back reinforcing-sewing 0: unavailable 1: available	0/1	1	0	I
P-19	Solid after before sewing stop	0: unavailable 1: available	0/1	1	0	I
P-20	Function selection of machine head button	0: invalid 1: Manual thread cutting while standby 2: Manual presser foot after trimming	0/1/2	1	0	I
P-21	soft start speed 1	speed of the 1 st needle of soft start	100~3000(rpm)	50	400	I
P-22	soft start speed 2	speed of the 2 nd needle of soft start	100~3000(rpm)	50	1000	I
P-23	soft start speed 3	speed of the 3 rd~9 th needle of soft start	100~3000(rpm)	50	1500	I
P-24	Presser foot soft lowering function	Setting to protect damaged the fabric to slow down the presser foot lowering speed	0/1	1	1	I
P-25	Presser foot lift function	0: unavailable 1: available	0/1/2	1	1	I
P-26	Function of over thickness	Setting the function of over thickness 0: unavailable 1: available	0/1	1	0	I
P-27	Power on and positioning	The function setting of automatically finding the needle position when the power is on 0: unavailable 1: available	0/1	1	0	I
P-28	signal mode for turn/lift switch	Setting of signal mode of turn/lift switch of machine head 0: always open 1: always close 2: forbid a protection	0/1/2	1	0	I
P-29	Presser foot soft lowering time	To set presser foot soft lowering time The longer time the lower speed of the presser foot	100~500 (ms)	5	80	II
P-30	Baseline count enable	0: unavailable 1: available	0/1	1	0	I
P-31	Baseline initial value setting	Baseline initial value setting	20~4000 (0.1m)	20	1600	I
P-32	Stop time of decorative tacking sewing (effective for only presser foot)	Stop time of decorative tacking sewing setting	0~500(ms)	5	50	I
P-34	Standard joint speed mode selection	Select 0 automatic for standard joint speed mode; 1 pedal control	0/1	1	0	II
P-35	multiple ratio of counting by piece	Setting of multiple ratio of counting by piece	0~50	1	0	I
P-36	Setting initial value of counting by piece	Setting initial value of counting by piece	0~1000	5	100	I
P-37	Time of thread wiper	Time of thread wiper	0~800 (ms)	10	40	II
P-38	Setting function of choosing counting by piece	0: add 1: subtract	0/1	1	0	I
P-39	Turn off time before presser foot soft drop	Turn off time before presser foot soft drop	0~50	1	12	I
P-41	Low speed	The lowest speed of pedal	100~500(rpm)	10	200	I
P-42	Pedal curve selection	Pedal speed adjustment 0: normal 1: Slow acceleration 2: Quick acceleration	0/1/2	1	2	I
P-44	thread-cutting speed	thread-cutting speed	100~500(rpm)	10	300	I
P-45	Back-tracking speed limit function	Back-tracking speed processing can prevent reverse sewing needle breakage 0:1: infinite speed limit 2: the speed limit	0/1/2	1	0	I
P-46	presser foot lifting delays sewing	delay with presser foot lowered	0~800(ms)	10	100	II
P-47	When running, the knee presses the foot to judge the speed	When running, the knee presses the foot to judge the speed	200~1000(rpm)	50	500	II
P-48	When running the knee is raised by the foot	When running the knee is raised by the foot	1~100	1	0	II
P-49	Press foot holding time	Lift the pressure foot after holding time to force off	1~60(s)	1	25	II
P-50	output time of total pressure of presser foot lifting	output time of total pressure of presser foot lifting	0~800(ms)	10	150	II

P-51	output duty cycle of presser foot lifting hold time of presser foot lifting	output duty cycle of presser foot lifting hold time of presser foot lifting	0~100	1	40	II
P-53	starting reinforcing-sewing speed	starting reinforcing-sewing speed	100~3000(rpm)	50	2200	I
P-54	Compensation coefficient of front tacking sewing	Compensation coefficient of front tacking sewing	80~120	1	100	I
P-55	Compensation coefficient of front back tacking sewing	Compensation coefficient of front back tacking sewing	80~120	1	100	I
P-56	ending reinforcing-sewing speed	ending reinforcing-sewing speed	100~3000(rpm)	50	2200	I
P-57	starting reinforcing-sewing of front tacking sewing	starting reinforcing-sewing of front tacking sewing	80~120	1	100	I
P-58	starting reinforcing-sewing of front back tacking sewing	starting reinforcing-sewing of front back tacking sewing	80~120	1	100	I
P-59	Continuous reinforcing-sewing speed	Continuous reinforcing-sewing speed	100~3000(rpm)	50	2200	I
P-60	Bartack stitch cancel speed limit	0: The software has speed limited 1: No speed limited	0/1	1	0	I
P-61	A switch to cancel the angle limit when change stitch length	0: Change the stitch length within the limiting angle 1: Vhange stitch length at any angle (The stitch length may not coincide, or the needle may break)	0/1	1	0	I
P-62	Pedal travel upon start	Pedal position upon start (Travel relative to medium pedal)	10~50(0.1°)	1	25	II
P-63	Pedal travel upon acceleration	Pedal position upon start acceleration (Travel relative to medium pedal)	10~100(0.1°)	1	50	II
P-64	Pedal travel at highest rotation speed	Pedal position at highest rotating speed (Travel relative to medium pedal)	10~150(0.1°)	1	110	II
P-65	Pedal travel upon presser foot lift	Pedal position upon pedal lift (Travel relative to medium pedal)	-100~-10(0.1°)	1	-30	II
P-67	Pedal travel 1 upon thread trimming	Pedal position upon start trimming without presser foot function Travel relative to medium pedal	-100~-10(0.1°)	1	-30	II
P-68	Pedal travel 2 upon thread trimming	Pedal position upon start thread trimming with presser foot function (Travel relative to medium pedal)	-100~-10(0.1°)	1	-60	II
P-69	Down needle positioning position	To adjust down needle position	0~240	1	175	I
P-70	Reverse needle lift function	Reversal of needle lift function after thread trimming 0: unavailable 1: available	0/1	1	0	I
P-71	Reversal of needle lift angle	Reversal of needle lift angle	0~45°	1	20	I
P-72	Thread clamp strength adjustment	Adjust the thread clamp strength size 0: Clip line function is invalid 1~9: Three Intensity Adjustment	0~9	1	7	I
P-73	Thread pressing actuation angle	Thread pressing actuation angle	10~150°	5	100	I
P-74	Thread pressing release angle	Thread pressing release angle	160~300°	5	270	I
P-75	Needle position adjustment	Needle position adjustment	0~240	1	33	I
P-77	Setting of beauty sewing	0: unavailable 1: available	0/1	1	0	I
P-78	Beauty sewing (close sewing) mode setting	1: Close stitch on start sewing 2: Close stitch on end-sewing 3: Close stitch on both start and end sewing	1/2/3	1	2	II
P-79	return to factory-set parameter	Special functional parameters 5/8: Restore factory parameters	0~15	1	0	I
P-80	highest speed of sewing	highest speed of sewing	300~5000(rpm)	100	4000	II
P-81	Pedal speed percentage	Pedal speed percentage	50~100	1	100	II
P-83	Strength function	Try if the needle can't penetrate the cloth. 0: invalid; 1~15: intensity adjustment	0~15	1	0	II
P-84	Function of cutting line and adding force	Effective when the cutting wire is an electromagnet; 0: invalid; 1~15: intensity adjustment	0~15	1	0	II
P-88	Loose line suction Angle	Loose line suction Angle	0~360	2	180	II
P-89	Loose line release Angle	Loose line release Angle	0~360	2	350	II
P-90	Language selection setting	Setting of language: 0: turn off 1: Chinese 2: English	0~2	1	1	II
P-91	Change pitch selection	Change pitch selection 0: Changes Allowed 1: Allowed to change	0~1	1	0	II
P-92	Pedal presser foot lift confirm time	Pedal presser foot lift confirm time	10~300(ms)	10	80	II
P-93	The neutral position of the pedal	Trimming the neutral position of the pedal	-15~15(0.1degree)	1	0	II
P-95	Anti-nest function selection	Anti-nest function selection: 0: thread clamp type 1: Anti-next type 2: thread wiper type	0/1/2	1	0	II
P-100	Knee by function setting	Knee by function setting: 0: unavailable 1: available	0/1	1	1	II
P-101	The voltage at the zero position of the knee sensor	The voltage at zero position of knee by's presser foot (Unit:0.01V)	0~500	5	270	II
P-102	Knee sensor's voltage of maximum travel distance	Knee sensor's voltage of maximum travel distance (Unit:0.01V)	0~500	5	60	II
P-103	Line tension / loose line function switch	0: Line tension control 1: Ordinary loose line electromagnet control	0/1	1	1	II
P-104	Pattern stop function enable	0: unavailable 1: Stop the needle need to go through the current number of pattern stitches	0/1	1	0	II
P-105	Presser foot height sensor function setting	Presser foot height sensor function setting 0: unavailable 1: available	0/1	1	1	II
P-106	The voltage adjustment at zero position of presser foot height sensor	The voltage adjustment at zero position of presser foot height sensor (Unit:0.01v) (presser foot drop, feed dog is under the table.)	0~250	1	215	II
P-107	Overthickness detection sensitivity setting	Presser foot height sensor's voltage setting of overthickness detection (Unit:mv) (Relative to the zero position voltage)	0~500	5	100	II
P-108	Full pressure duty cycle of thread trimming	Full pressure duty cycle of thread trimming(Buffering during the thread trimming and closing)	50~100	1	80	II
P-109	Force adjustment of electromagnet for presser foot lifting	Force adjustment of electromagnet for presser foot lifting (Cushion when press foot is absorbed)	50~100	1	80	II
P-110	Material thickness and tension control	Increase tension when sewing thick material	0~10	1	0	II
P-111	Overthickness sewing speed	Limit speed of overthickness	500~3000(rpm)	50	1500	II
P-112	Overthickness stitch offset coefficient	Overthickness stitch offset deals	50~150(%)	1	120	II
P-113	Needle compensate stitch length mode	Needle compensate stitch length mode 0: Invalid; valid (press P114 to set stitch length)	0/1	1	0	I
P-114	Needle compensate stitch length setting	Needle compensate stitch length setting Parameter range of stitch length 5mm type(1.0mm~5.0mm) Parameter range of stitch length 5mm type(1.0mm~7.0mm)	10~50 (70)	1	35	I
P-115	Reverse sewing button function setting	0: reverse sewing 1: tightly sewn 2: reverse sewing 3:reverse sewing+reverse sewing	0~3	1	0	II
P-116	fill needle button function setting	0: reverse sewing 1: tightly sewn 2: reverse sewing 3:reverse sewing+reverse sewing	0~3	1	2	II
P-117	Dense needle pitch setting	Head button stitch stitch set	50~150	1	110	II
P-118	Number of pretty sewing needle setting	Number of pretty sewing needle setting	1~10	1	1	II
P-119	Pretty sewing needle distance setting	Pretty sewing needle distance setting	50~150	1	110	II
P-121	Start trimming angle of Paragraph 1	Start trimming angle of Paragraph 1	200~300	2	230	II
P-122	Paragraph 1 stroke of trimming	Paragraph 1 stroke of trimming	0~100	1	40	II
P-123	Start trimming angle of Paragraph 2	Start trimming angle of Paragraph 2	250~360	2	330	II
P-124	Paragraph 2 stroke of trimming	Paragraph 2 stroke of trimming	0~100	1	65	II
P-125	Stop and trimming during fixed-length sewing	0: invalid 1: valid	0/1	1	0	II
P-126	loose thread enable when start sewing	0: invalid 1: valid	0/1	1	1	II
P-127	Delay before start-sewing loose thread	Delay before start-sewing loose thread	0~1000	10	100	II
P-128	Action time of loose thread when start-sewing	Action time of loose thread when start-sewin	0~1000	10	200	II
P-129	Display backlight brightness Setting	Display backlight brightness Setting	0~10	1	5	I
P135	Midway reverse function selection	0: unavailable 1: available	0~1	1	0	I
P136	The number of midway stitch set	Pin setting	1~50	1	4	I
P137	Seam midway down the number of times back and forth set	Set times	1~10	1	1	I
P-138	Lock screen function setting	Lock screen function setting: 0: invalid 1: valid	0~1	1	1	I
P-139	Lock screen time setting	Lock screen time setting: 0~240 (s)	0~240	1	2	I
P-140	Delay time before thread hooking of Anti-nest	The delay time between the end of trimming and the hook	0~500ms	5	50	II
P-141	Thread hooking time of Anti-nest	The action time of the hooked electromagnet	0~500ms	5	50	II
P-142	Delay after Anti-nest hook	The delay time of the hook electromagnet turning off	0~500ms	5	50	II
P-143	Thread hooking duty ratio of Anti-nest	Adjust the action force of the hooked electromagnet	0~100	1	100	II
P-144	Anti-nest suction work time	The work time of the suction valve	0~2000ms	10	250	II
P-145	Thread-straight work time of Anti-nest	The work time of a thread-straight solenoid	0~500ms	5	50	II
P150	Maximum stitch length setting	Maximum needle distance setting stitch length 5mm model parameter scale (1.0mm~5.0mm) stitch length 7mm model parameter scale (1.0mm~7.0mm)	10~50 (70) mm	1	50	II
P-151	First off-line prevented stitch length	0: invalid 1: valid	0~1	1	0	II
P-152	First off-line prevented stitch length setting	Stitch length setting Parameter range (1.0mm~5.0mm)	10~50	1	40	II
P-153	Head button inching mode setting	0: invalid 1: valid (Press once valid, press again cancel, such as close sewing, over thickness, presser foot)	0~1	1	0	II
P-155	Needle bar lamp brightness setting	0: Needle bar light off 1~5: Adjust the brightness of needle bar lamp of 5 gears (HMI control 0/1/2/3/4/5/switch)	0~5	1	5	II
P-157	Back sewing switch function setting	Back sewing mode setting 0: Back sewing only 1: back sewing plus attach stitch 2: Back sewing only, no action in standby mode	0/1/2	1	0	I

P-158	Full pressure output time of back sewing (only presser foot, thread trimming)	Full pressure output time of presser foot	0~800(ms)	10	150	II
P-159	Output duty cycle of back sewing (only presser foot, thread trimming)	Output duty cycle of presser foot	0~100	1	40	II
P-160	Backing sewing duration	Forced turnoff after back sewing duration	0~60 (S)	1	12	II
P-161	Front tacking sewing compensation1(only presser foot, thread trimming)	Stitch compensation parameters of front tacking sewing	0~100	1	23	I
P-162	Front tacking sewing compensation2(only presser foot, thread trimming)	Stitch compensation parameters of front tacking sewing	0~100	1	15	I
P-163	ending reinforcing-sewing compensation1 (only presser foot, thread trimming)	Stitch compensation parameters of ending reinforcing-sewing	0~100	1	30	I
P-164	ending reinforcing-sewing compensation2 (only presser foot, thread trimming)	Stitch compensation parameters of ending reinforcing-sewing	0~100	1	18	I
P-165	Continuous reinforcing-sewing compensation1 (only presser foot, thread trimming)	Stitch compensation parameters of Continuous reinforcing-sewing	0~100	1	30	I
P-166	Continuous reinforcing-sewing compensation2 (only presser foot, thread trimming)	Stitch compensation parameters of Continuous reinforcing-sewing	0~100	1	10	I
P-170	Compensate system enablement by speed	=0, P171~P176 Invalid parameter =1, P171~P176 Invalid parameter	0~1	1	1	II
P-171	Speed clockwise sewing compensation	Speed clockwise sewing compensate system	50~150	1	100	II
P-172	Speed anti-clockwise sewing compensation	Speed anti-clockwise sewing compensate system	50~150	1	100	II
P-173	Starting reinforcing-sewing speed Clockwise sewing compensation	Speed Clockwise sewing compensation coefficient	50~150	1	100	II
P-174	Starting reinforcing-sewing speed Anti-clockwise sewing compensation	Speed Anti-clockwise sewing compensation coefficient	50~150	1	100	II
P-175	ending reinforcing-sewing speed Clockwise sewing compensation	Speed Clockwise sewing compensation coefficient	50~150	1	100	II
P-176	ending reinforcing-sewing speed Anti-clockwise sewing compensation	Speed Anti-clockwise sewing compensation coefficient	50~150	1	100	II
P-180	Compensate system enablement by stitch length	=0, P181~P200 Invalid parameter =1, P181~P200 Invalid parameter	0~1	1	1	II
P-181	1mm Clockwise sewing compensation	1mm Clockwise sewing compensation coefficient	50~150	1	100	II
P-182	1mm Anti-clockwise sewing compensation	1mm Anti-clockwise sewing compensation coefficient	50~150	1	100	II
P-183	2mm Clockwise sewing compensation	2mm Clockwise sewing compensation coefficient	50~150	1	100	II
P-184	2mm Anti-clockwise sewing compensation	2mm Anti-clockwise sewing compensation coefficient	50~150	1	100	II
P-185	3mm Clockwise sewing compensation	3mm Clockwise sewing compensation coefficient	50~150	1	100	II
P-186	3mm Anti-clockwise sewing compensation	3mm Anti-clockwise sewing compensation coefficient	50~150	1	100	II
P-187	4mm Clockwise sewing compensation	4mm Clockwise sewing compensation coefficient	50~150	1	100	II
P-188	4mm Anti-clockwise sewing compensation	4mm Anti-clockwise sewing compensation coefficient	50~150	1	100	II
P-189	5mm Clockwise sewing compensation	5mm Clockwise sewing compensation coefficient	50~150	1	100	II
P-190	5mm Anti-clockwise sewing compensation	5mm Anti-clockwise sewing compensation coefficient	50~150	1	100	II
P-191	6mm Clockwise sewing compensation	6mm Clockwise sewing compensation coefficient	50~150	1	100	II
P-192	6mm Anti-clockwise sewing compensation	6mm Anti-clockwise sewing compensation coefficient	50~150	1	100	II
P-193	7mm Clockwise sewing compensation	7mm Clockwise sewing compensation coefficient	50~150	1	100	II
P-194	7mm Anti-clockwise sewing compensation	7mm Anti-clockwise sewing compensation coefficient	50~150	1	100	II

PARTS BOOK

Please confirm the relative applications, reference number and part number when buying the parts.

1. Machine Frame Mechanism

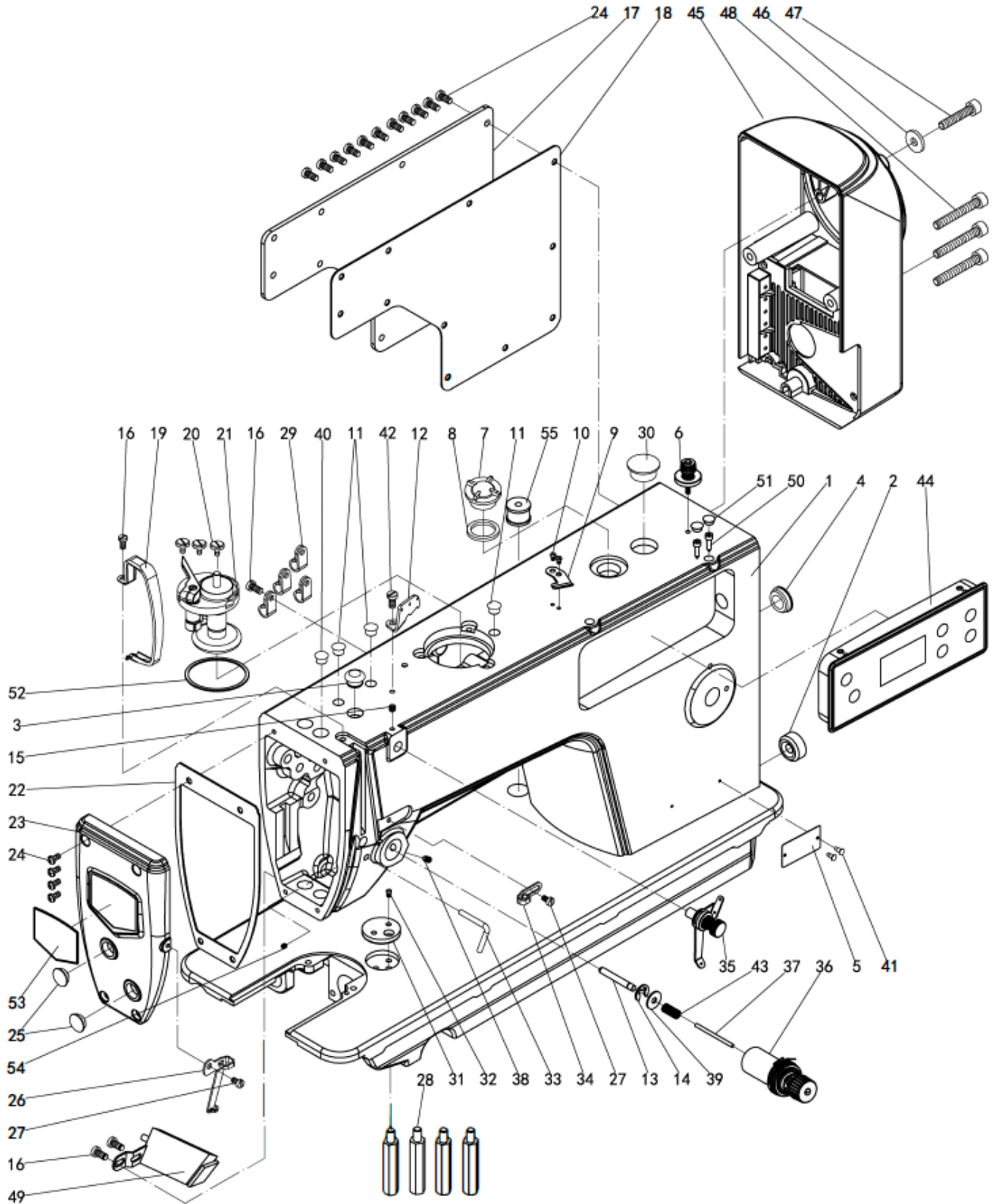

1. Machine Frame Mechanism

No.	Part No.	Qty.	Description
1	312110001	1	Frame
	312110010	1	Frame
2	307010014	1	Plug
3	306010008	1	Plug
4	302010048	1	Plug
5	402020047	1	Type plate
6	306020003	1	Thread tension asm.
7	306010009	1	Oil window
8	306010010	1	Rubber ring
9	502070009	1	Secant cutter
10	404450033	2	Screw SM9/64×40 L=5
11	306010026	3	Plug
12	306010029	1	Thread guide
13	306010012	1	Pin
14	404610001	1	E-ring
15	404440005	1	Screw SM11/64×40 L=5
16	404420008	4	Screw SM3/16×28 L=6
17	302910110	1	Side plate
18	307010018	1	Side plate gasket
19	302010128	1	Thread take-up lever cover
20	404450023	3	Screw M5 L=10
21	302010023	1	Bobbin wider asm.
22	312010003	1	Face plate gasket
23	312010002	1	Face plate
24	404420009	15	Screw SM3/16×28 L=9
25	306010028	2	plug
26	306010149	1	Thread guide
27	404450021	2	Screw SM11/64×40 L=6
28	306010030	4	Frame leg
29	206115	4	Clip
30	306010027	1	Plug
31	307010007	1	Ruler plate
32	404450024	1	Screw SM11/64×40 L=5
33	306010002	1	Thread guide
34	306010031	1	Thread guide
35	306020004	1	Upper thread take-up device asm.
36	306020032	1	Thread tension asm.
	302010068	1	Thread tension asm.
37	306010033	1	Pin
38	404440007	1	Screw SM15/64×28 L=10.5
39	302010074	1	Oil pad
40	404130001	1	Plug
41	401040041	2	Rivet
42	404420024	1	Screw SM11/64×40 L=8
43	306010055	1	Spring
44	312020004	1	Display operation panel component
45	312020005	1	Electronic control box asm.
46	404210011	1	Washer ø5.5×ø10×1
47	404430023	1	Screw M5 L=20
48	404430032	3	Screw M5 L=35
49	302030003	1	Automatic reverse seam switch asm.
50	404430036	2	Screw M3 L=12
51	404130007	2	Plug
52	306010132	1	Oil gasket
53	402020052	1	Type plate
54	4543	1	Screw M4 L=4
55	307010011	1	Plug

2. Main Shaft and Thread Take-up & Needle Bar Mechanism

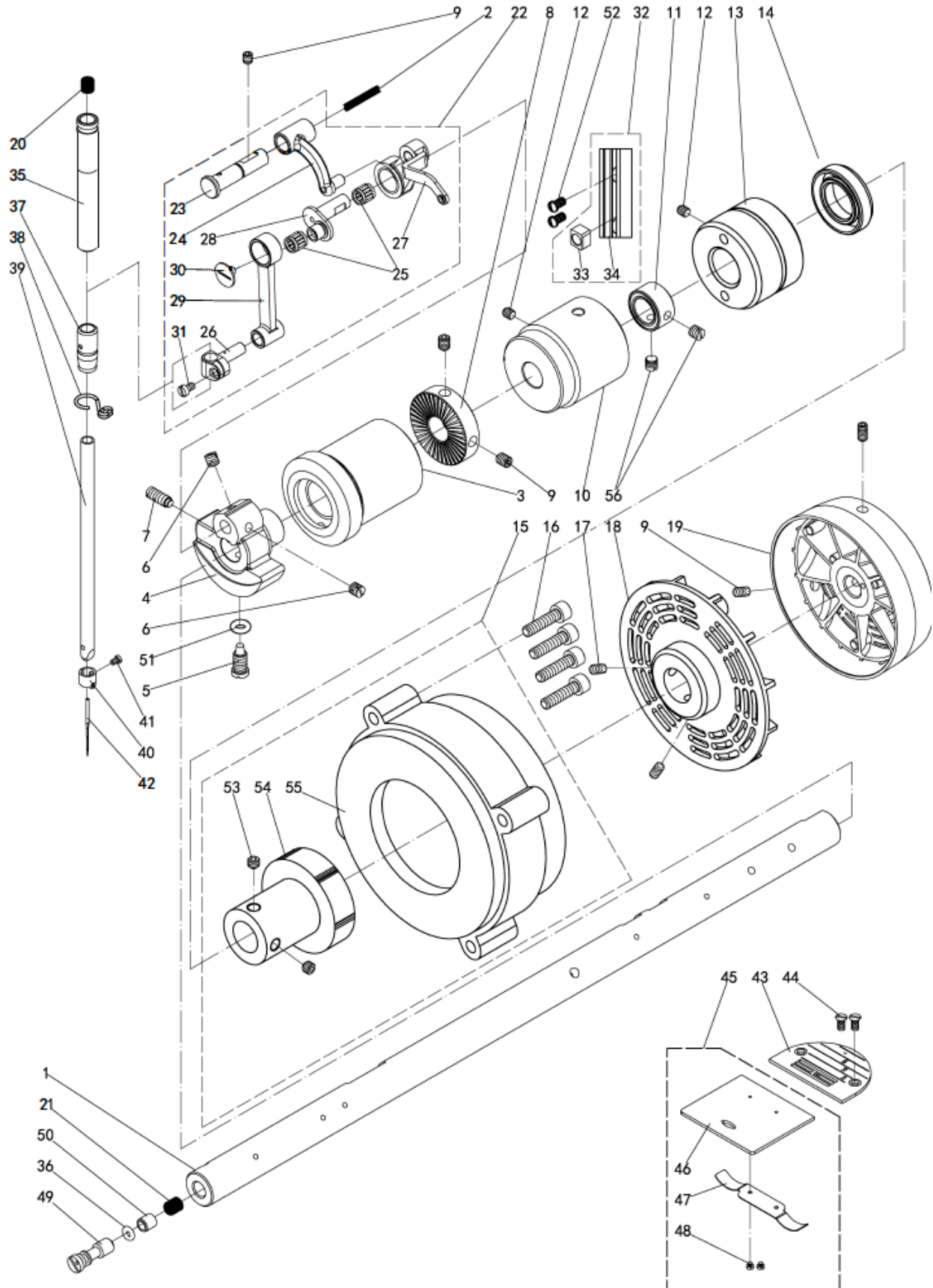

2. Main Shaft and Thread Take-up & Needle Bar Mechanism

No.	Part No.	Qty.	Description
1	302020026	1	Main shaft
2	109010519	1	oil line
3	307010015	1	Sleeve
4	301010036	1	Needle bar crank
	306010021	1	Needle bar crank
5	306010042	1	Screw SM9/32×28
6	404440008	2	Screw SM1/4×40 L=6
7	306010043	1	Screw SM9/32×28 L=16
8	302010024	1	Winder drive wheel
9	4572	5	Screw M5 L=10
10	302010038	1	Sleeve
11	306010035	1	Collar
12	404440006	2	Screw SM15/64×28 L=10.5
13	307010016	1	Shaft sleeve
14	307010041	1	Oil seal $\phi 15 \times \phi 27 \times 7$
15	307010005	1	Motor
16	404430014	4	Screw M5 L=30
17	4522	2	Screw M6 L=6
18	307010006	1	Blades
19	307910004	1	Head wheel
20	302010077	1	Felt
21	302010076	1	Flet
22	301010048	1	Thread take-up lever asm.
	307020030	1	Thread take-up lever asm.
23	-	1	Connecting rod pin
24	-	1	Connecting rod
25	-	2	Needle bearing
26	-	1	Needle bar holder
27	-	1	Thread take-up lever unit
28	-	1	Thread take-up crank
	-	1	Thread take-up crank
29	-	1	Connecting rod
30	-	1	Screw 9/64×40 L=6
31	-	1	Screw SM9/64×40 L=7
32	301010047	1	Slider
33	-	1	Slider
34	-	1	Slider
35	301010018	1	Sleeve
36	404110008	1	O-ring
37	301010019	1	Sleeve
	302010064	1	Sleeve
38	302010065	1	Thread guide
39	301010303	1	Needle bar
40	301010020	1	Thread guide
41	404450049	1	Screw SM1/8×44 L=4
42	502020016	1	Needle-DBX1/14
	502020015	1	Needle-DBX1/18
43	307010012	1	Needle plate
44	5484	2	Screw SM11/64×40 L=9
45	306020005	1	Push plate asm.
46	-	1	Push plate
47	-	1	Push plate spring
48	-	2	Screw SM3/32×56 L=2
49	306010076	1	Oil amount adjusting pin
50	306010077	1	Rubber ring
51	404110009	1	O-ring
52	404450011	2	Screw SM9/64×40 L=7.5
53	-	2	Screw M6 L=6
54	-	1	Motor rotor
55	-	1	Motor stator
56	302010616	2	Screw SM1/4×40 L=6

3. Hang Lifter Mechanism

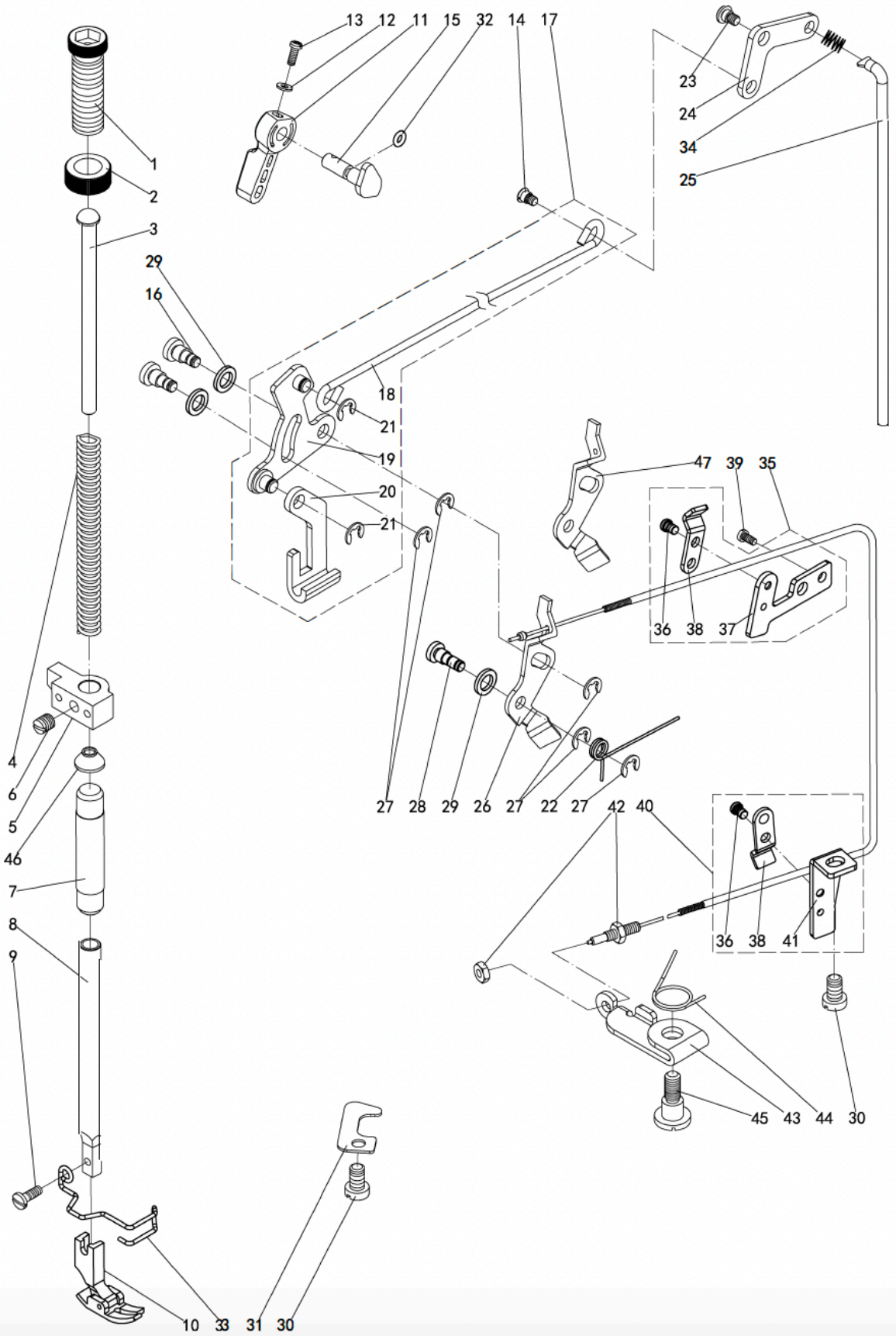

3. Hang lifter Mechanism

No.	Part No.	Qty.	Description
1	307010010	1	Pressure adjusting screw
2	307010019	1	Pressure adjusting nut
3	306010046	1	Pressure guide bar
4	306010047	1	Spring
	306010093	1	Spring H
5	301010045	1	Pressure guide bar bracket
6	404440010	1	Screw SM1/4×40 L=8
7	301010046	1	Sleeve
8	301010044	1	Presser bar
9	404450025	1	Screw SM9/64×40 L=10.5
10	302010049	1	Presser food asm.
	302010063	1	Presser food asm.H
11	301010028	1	Hand lifter
12	301010031	1	Washer $\phi 3.7 \times \phi 8 \times 0.8$
13	404420010	1	Screw SM9/64×40 L=10
14	306010049	1	Screw
15	306010011	1	Hand lifter CAM
16	306010051	2	Screw
17	301010014	1	Lifting cross rod asm.
18	-	1	Lifting lever connecting rod
19	-	1	Hand lift link
20	-	1	Lifting lever
21	-	2	E-ring
22	306010052	1	Spring
23	404410005	1	Screw
24	301010015	1	Lifting lever link
25	301010016	1	Mandril
26	306020053	1	Thread tension release wire asm.
27	404610003	5	E-ring
28	306010050	1	Screw
29	306010056	3	Seal ring
30	404420011	2	Screw SM15/64×28 L=8
31	306010057	1	Wire cable holder
32	301010030	1	O-ring
33	302010071	1	Hand guard
34	306010448	1	Spring
35	306020006	1	Thread tension release wire holder
36	-	2	Screw SM11/64×40 L=7
37	-	1	Wire holder bracket
38	-	2	Wire holder
39	404420008	1	Screw SM3/16×28 L=6
40	306020007	1	Thread tension release wire holder
41	-	1	Wire holder bracket
42	404510006	2	Nut SM3/16×32
43	306010094	1	Thread loose seat
44	306010095	1	Spring
45	404410009	1	Screw
46	306010143	1	Oil seal
47	306010053	1	Thread tension release wire asm.

4. Feed Mechanism

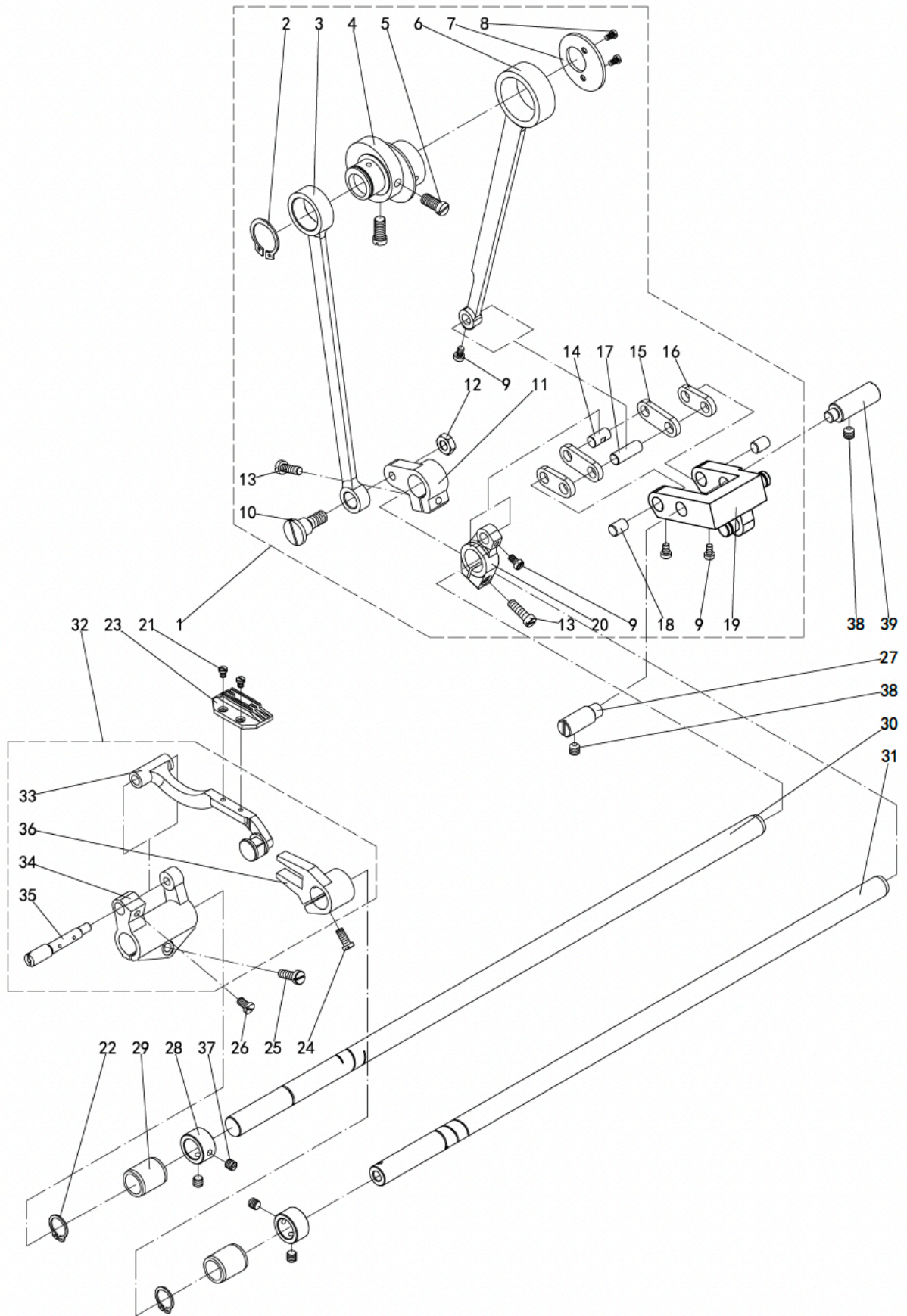

4. Feed Mechanism

No.	Part No.	Qty.	Description
1	302010052	1	Feeding assembly
	302110052	1	Feeding assembly H
2	-	1	External Circlips $d_0=20$
3	-	1	Lifting link
4	-	1	Feeding eccentric CAM
	-	1	Feeding eccentric CAM H
5	-	2	Screw SM1/4×40 L=13
6	-	1	Feeding link
7	-	1	Feeding eccentric CAM cover
8	-	2	Screw SM9/64×40 L=6
9	404450014	4	Screw SM9/64×40 L=6
10	-	1	Axial screw
11	-	1	Lift link crank
12	-	1	Screw SM9/32×28
13	404450026	2	Screw SM3/16×28 L=14
14	-	1	Feeding rod crank pin
15	-	2	Feeding long swing plate
16	-	2	Feeding short swing plate
17	-	1	Feeding rod pin
18	-	2	Feed short swing plate connecting pin
19	-	1	Feed swing plate seat unit
20	-	1	Feed rod crank
21	404450036	2	Screw SM1/8×44 L=6
22	404620003	2	External Circlips $d_0=15$
23	307010013	1	Feeding dog
	306010161	1	Feeding dog
24	404450027	1	Screw SM11/64×40 L=10.5
25	404450026	1	Screw SM3/16×28 L=14
26	404450028	1	Screw SM11/64×40 L=8
27	306010060	1	Feeding swing base pin
28	301010011	2	Collar
29	302010036	2	Sleeve
30	302010030	1	Feed shaft
31	301010013	1	Lifting shaft
32	302010051	1	Feed bar asm.
	302010062	1	Feed bar asm. H
33	-	1	Feed bar unit
34	-	1	Feed bar driving crank
35	-	1	Pin
36	-	1	Lift fork crank
	-	1	Lift fork crank H
37	302010616	4	Screw SM1/4×40 L=6
38	404440006	2	Screw SM15/64×28 L=10.5
39	306010066	1	Feeding swing base pin

5. Feed Adjusting Mechanism

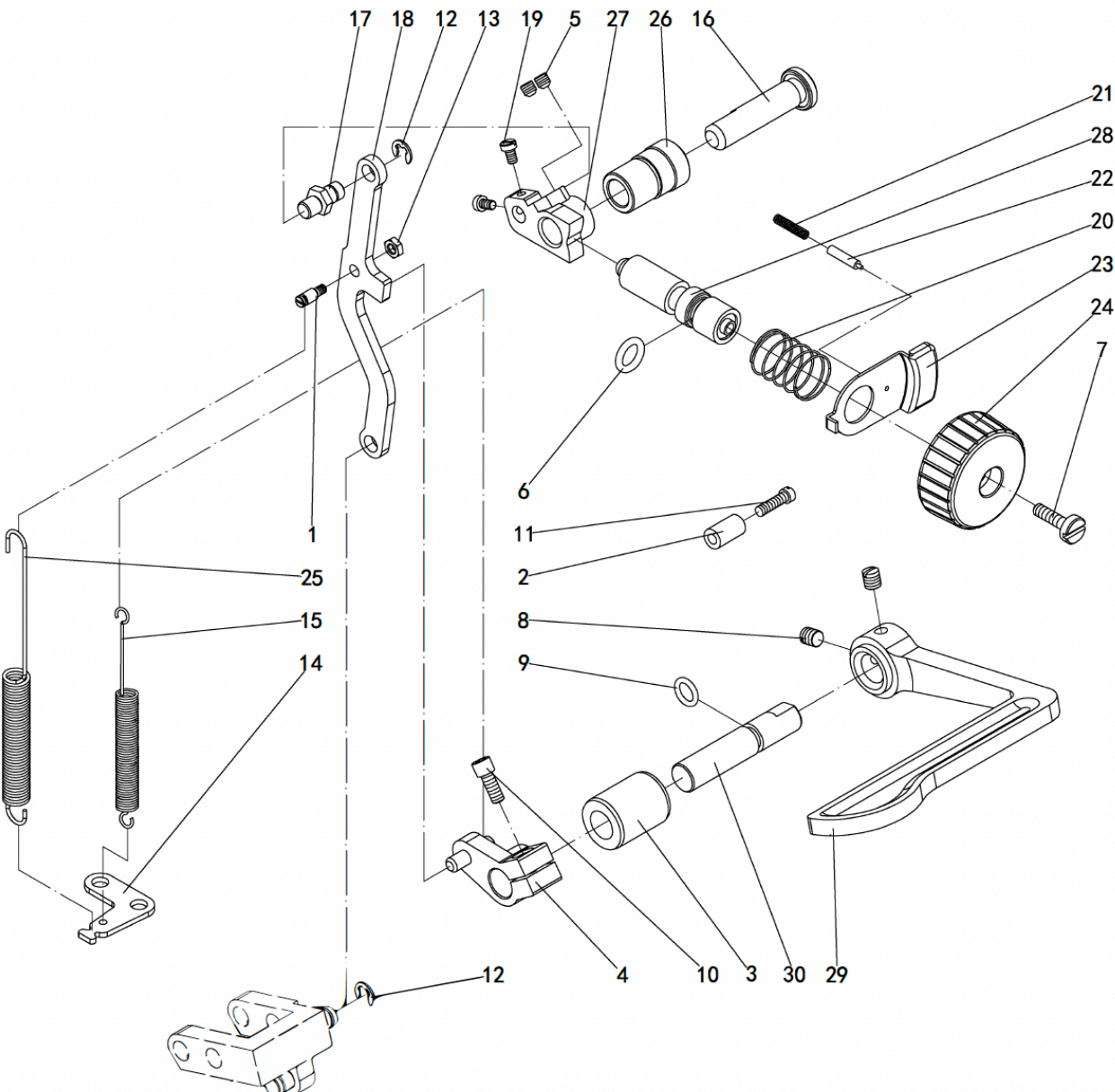

5. Feed Adjusting Mechanism

No.	Part No.	Qty.	Description
1	306010424	1	Rocker plate reset pin
2	306010065	1	Rubber sleeve
3	302010035	1	Sleeve
4	301010038	1	Reverse feed crank
5	4514	2	Screw M5 L=5
6	404110006	1	O-ring
7	404450029	1	Screw SM3/16×28 L=18
8	404440007	2	Scrc SM15/64×28 L=7
9	404110007	1	O-ring
10	404430024	1	Screw SM3/16×28 L=15.5
11	404450031	1	Screw SM3/16×28 L=18
12	404610003	2	E-ring
13	404510005	1	Nut SM11/64×40
14	306010058	1	Tension spring fixing plate
15	306010059	1	Spring
16	307010008	1	Feed regulator shaft
17	302010054	1	Reverse feed rod eccentric pin
18	306010430	1	Feed adjusting rod
	306010150	1	Feed adjusting rod
19	404450030	2	Screw SM9/64×40 L=6
20	302010044	1	Spring
21	10127010	1	Spring
22	306010062	1	Pin
23	306010063	1	Feed pitch adjustment button
24	306010064	1	Feed pitch adjustment knob
25	306010444	1	Spring
26	307010009	1	Sleeve
27	302010045	1	Feed regulator
	306010096	1	Feed regulator H
28	306010061	1	Feed adjusting bolt
29	302010565	1	Reverse feed wrench
30	302010028	1	Reverse feed shaft

6. Hook of Driving Shaft Mechanism

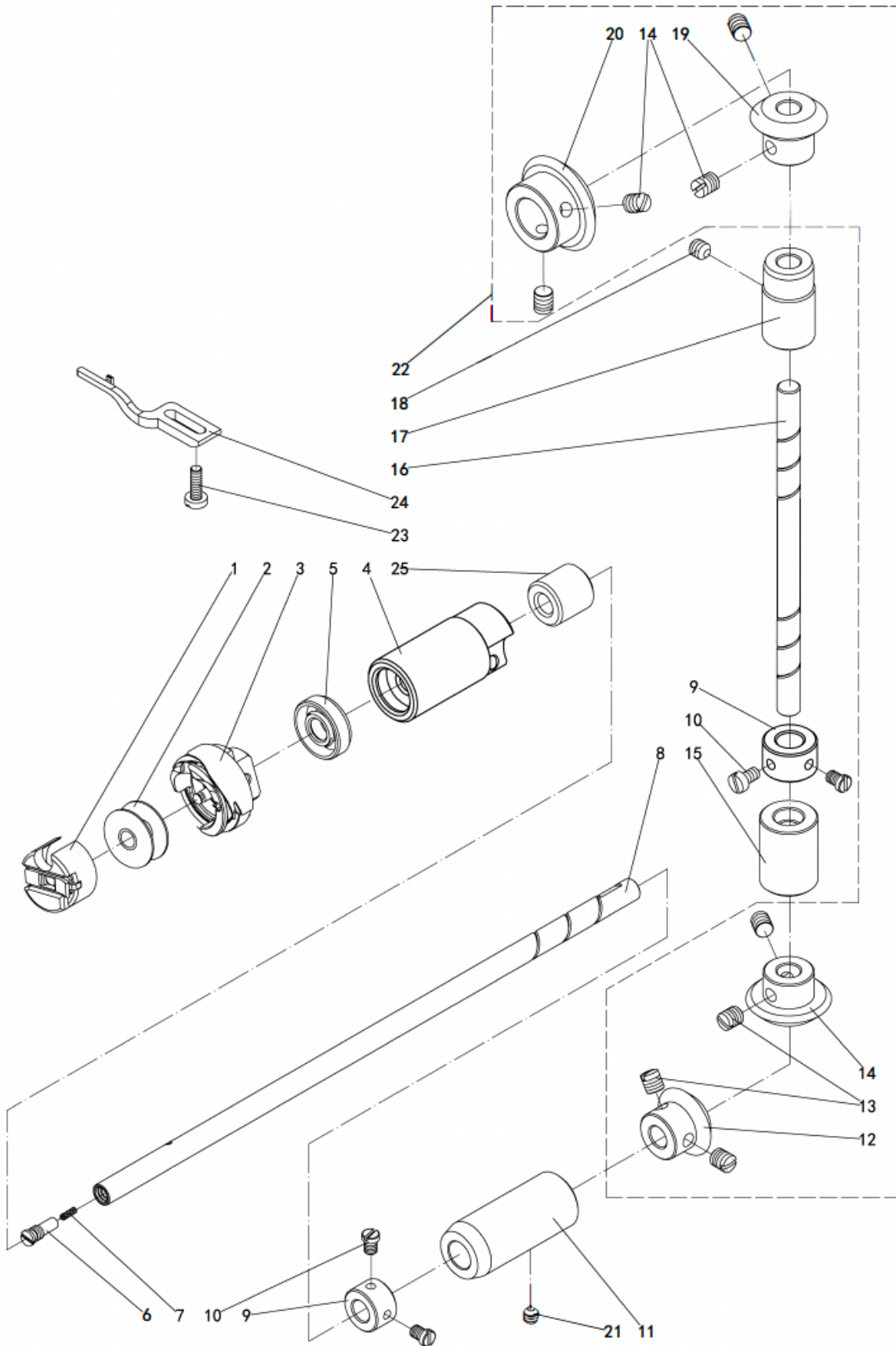

6. Hook of Driving Shaft Mechanism

No.	Part No.	Qty.	Description
1	306010067	1	Bobbin case
2	306010069	1	Bobbin
3	302010079	1	Hook
	302010078	1	Hook H
4	307010022	1	Sleeve
	302010039	1	Sleeve
5	404120008	1	Oil seal
6	306010074	1	Hook driving shaft oil limit screw
7	306010075	1	Hook driving shaft oil limit wick
8	302010027	1	Hook driving shaft
9	306010073	2	Collar
10	404450032	4	Screw SM11/64×40 L=5
11	302010041	1	Sleeve
12	-	1	Bevel gear
13	404440010	8	Screw SM1/4×40 L=8
14	-	1	Bevel gear
15	302010034	1	Sleeve
16	302010029	1	Upright shaft
17	301010005	1	Sleeve
18	404440007	1	Screw SM15/64×28 L=7
19	-	1	Bevel gear
20	-	1	Bevel gear
21	404440006	1	-
22	307010142	1	Bevel gear group
23	5118	1	Screw SM11/64×40 L=12
24	306010082	1	Positioning finger
	306010097	1	Positioning finger H
25	302010040	1	Sleeve

7. Lubrication Mechanism

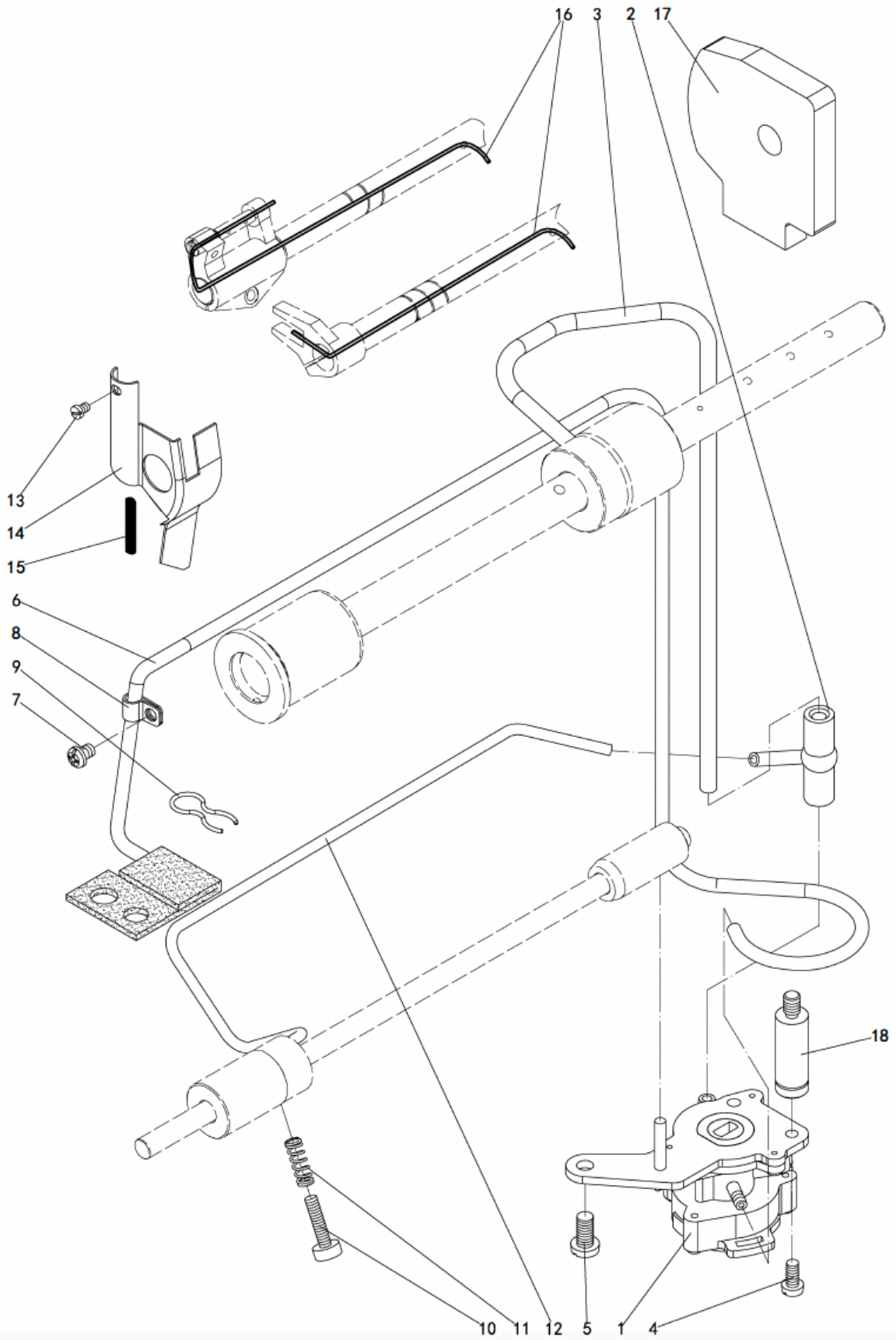

R

No.	Part No.	Qty.	Description
1	301010041	1	Lubricating oil pump asm
2	306010083	1	Rubber joint
3	306010086	1	Main shaft oil tube
4	5118	1	Screw SM11/64×40 L=12
5	404420011	1	Screw SM15/64×28 L=8
6	302010075	1	Oil felt
7	404420008	1	Screw MSM3/16×28 L=6
8	306010089	1	Oil return tube Holder
9	306010084	1	Oil felt presser
10	307010020	1	Oil adjusting screw SM15/64×28 L=24
	306010090	1	Oil adjusting screw SM11/64×40 L=19
11	307010021	1	Oil djusting spring
	306010085	1	Oil djusting spring
12	307010033	1	Oil tube
	306010088	1	Oil tube
13	404450022	1	Screw SM1/8×44 L=4
14	306010034	1	Arm oil shifld
15	202175	1	Oil line
16	202175	2	Oil line
17	306010092	1	Sponge
18	306010091	1	Screw

8. Oil Reservoir and Knee Pan Plate Mechanism

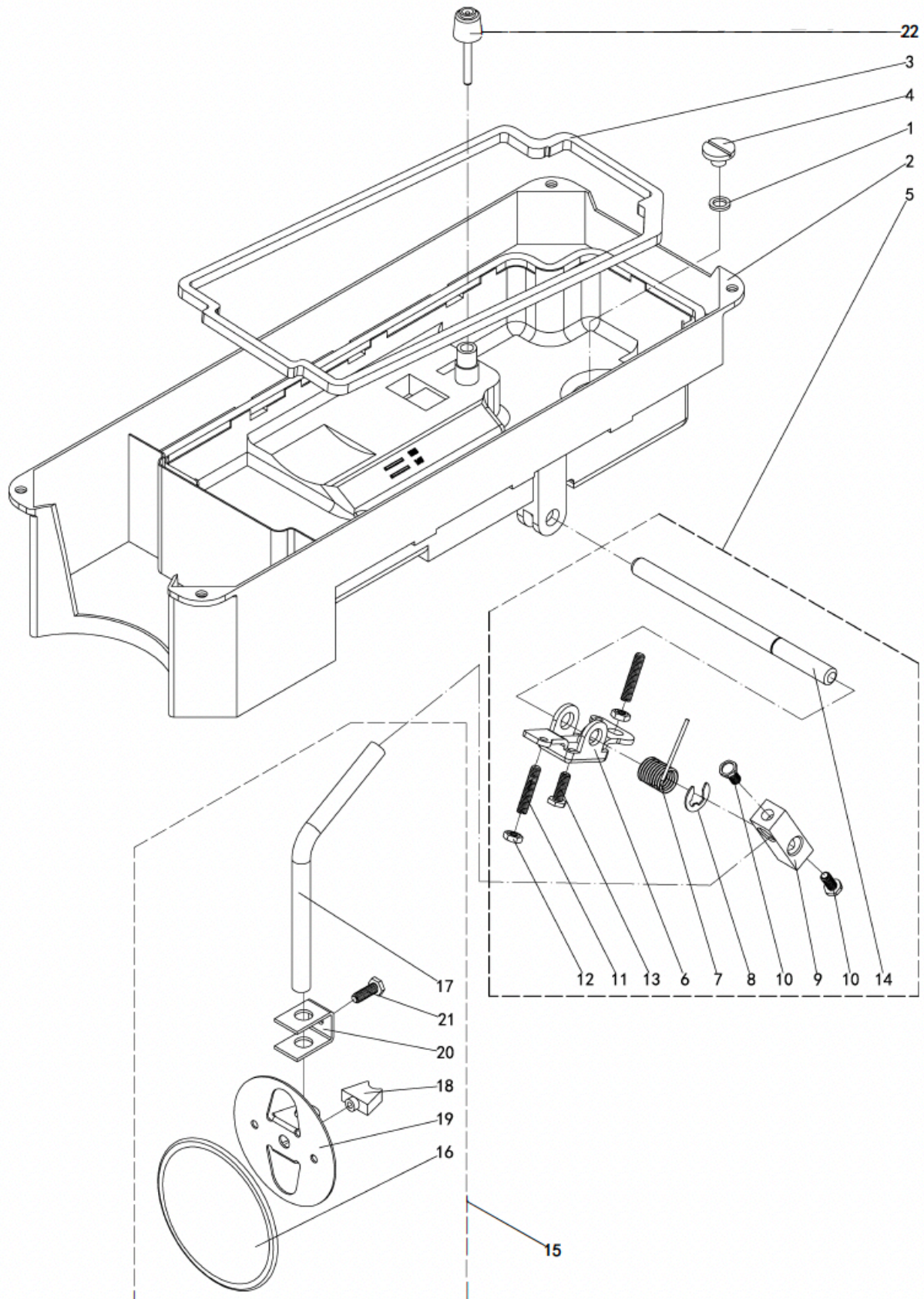

8. Oil Reservoir and Knee Pan Plate Mechanism

No.	Part No.	Qty.	Description
1	306010056	1	Rubber ring
2	301010024	1	Oil reservoir
3	301010025	1	Oil reservoir gasket
4	306010098	1	Screw SM5/16×24 L=7
5	306020099	1	knee lifting parts group
6	-	1	Knee lifting rotating arm
7	-	1	Spring
8	-	1	E-ring
9	-	1	Vertical shaft fitting arm
10	-	2	Screw M6 L=13
11	-	2	Screw M6 L=30
12	-	2	Nut M6
13	-	1	Screw M6 L=17.5
14	-	1	Knee press cross shaft
15	306010156	1	Knee pan plate asm
16	-	1	Knee pan plate cover
17	-	1	Knee pan upring shaft
18	-	1	Knee pan plate rubber
19	-	1	Knee pan plate
20	-	1	Knee pan plate support
21	-	1	Screw M6 L=12
22	306010103	1	Knee lifter push rod

9. Accessories Part Mechanism

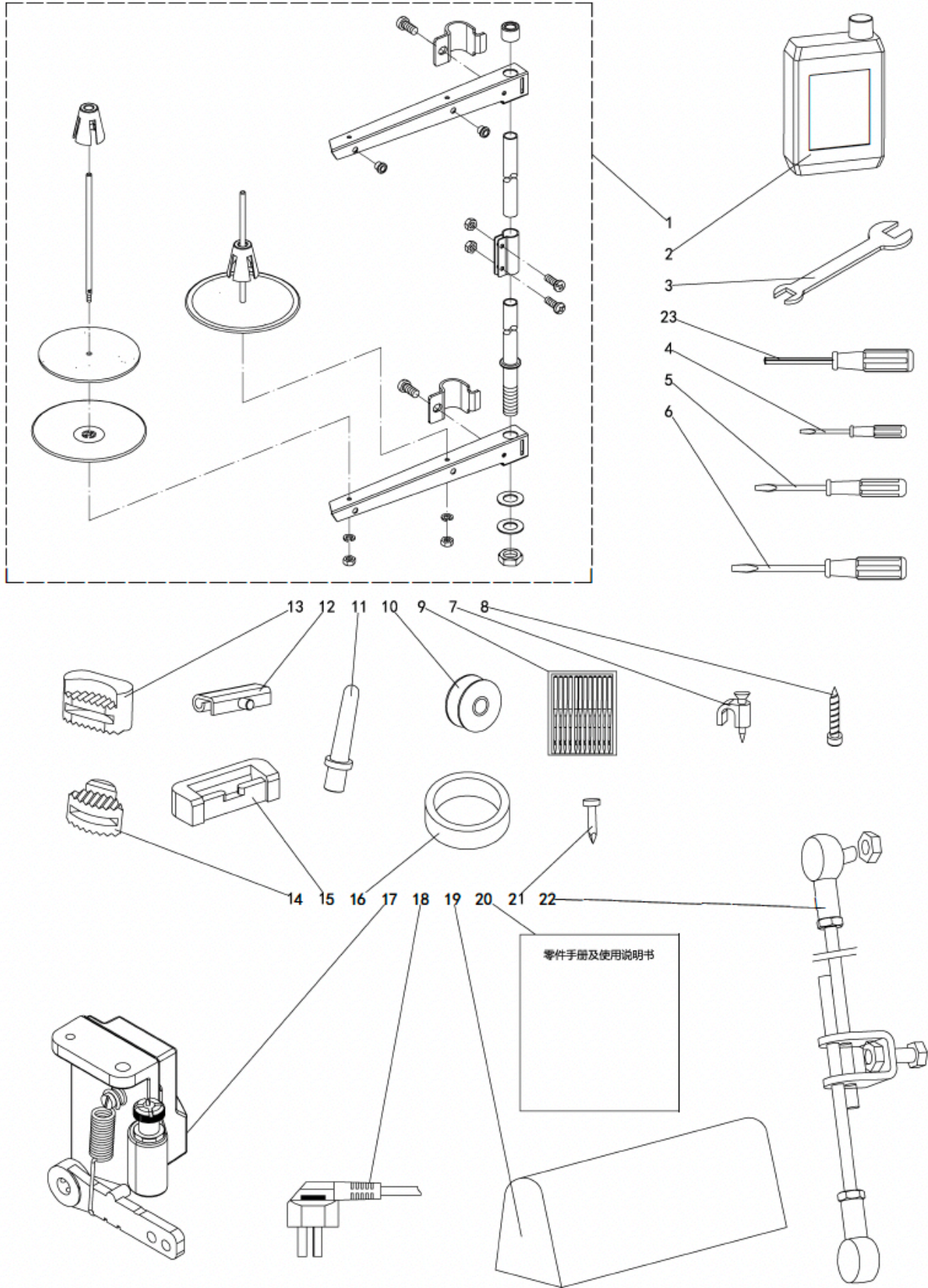

9. Accessories Part Mechanism

No.	Part No.	Qty.	Description
1	402020023	1	Thread stand asm.
2	402020005	1	Oil box
3	402020140	1	Wrench 8-9
4	402020067	1	Screw driver
5	402020066	1	Screw driver
6	402020065	1	Screw driver
7	-	4	Clips
8	404490008	4	Wood screw
9	405120011	10	Needle-DBX1/14
	502020015	10	Needle-DBX1/18
10	306010068	2	Bobbin
11	306010017	1	Head pole
12	306010104	2	Head connecting hook
13	306010105	2	Shockproof pad
14	306010106	2	Shockproof pad
15	306010107	2	Head connecting hook socket
16	306010108	1	Oil reservoir magnet
17	401030025	1	Pedal unit asm.
18	-	1	Power line
19	402020084	1	Dust cover
20	312010006	1	Instruction Book & Parts Book
21	306010109	6	Screw
22	401070002	1	Pedal control rod asm.
23	402020078	1	2mm Allen wrench

10. Thread Trimmer Mechanism

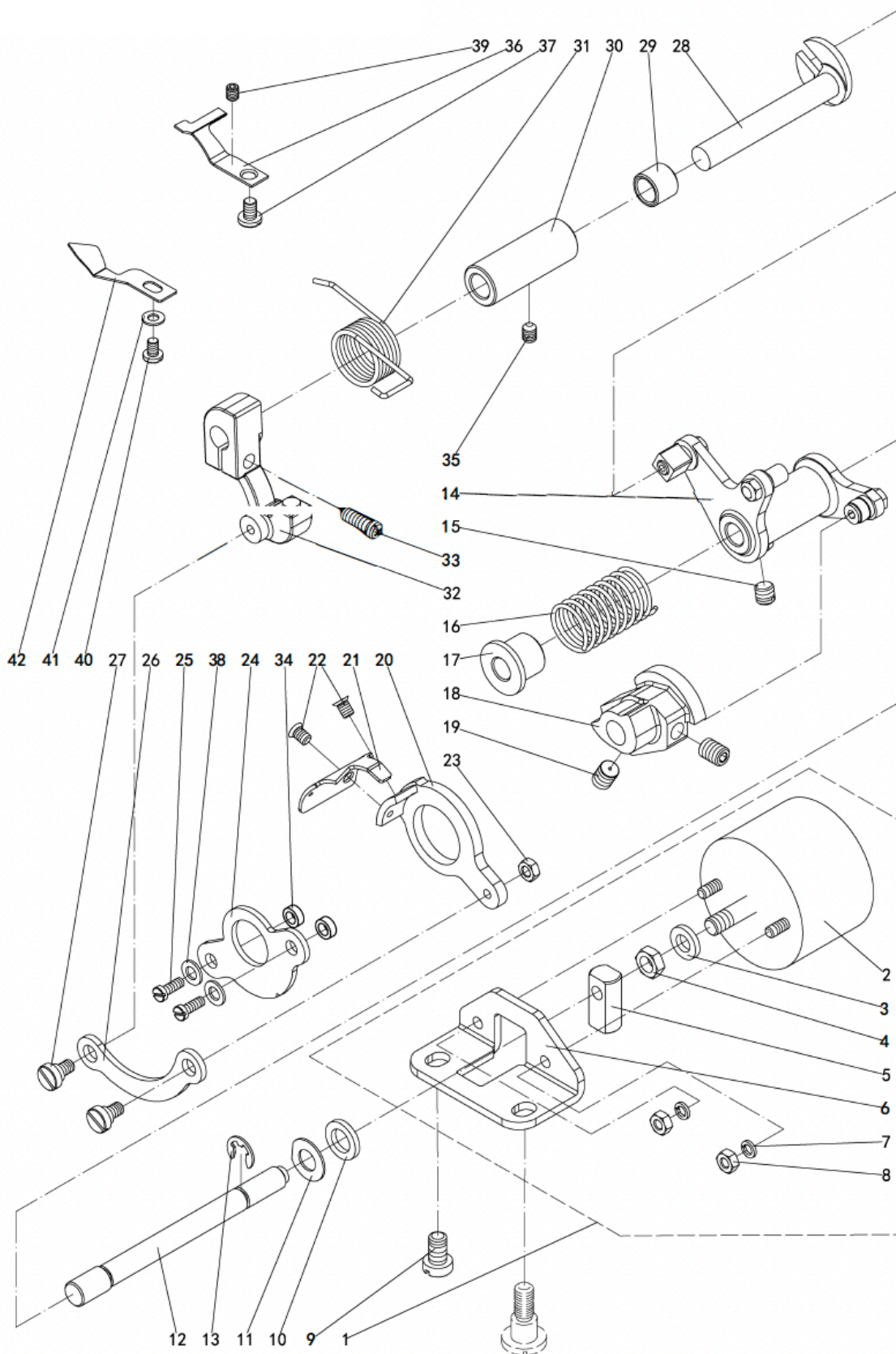

10. Thread Trimmer Mechanism

No.	Part No.	Qty.	Description
1	302010010	1	Thread trimmer electromagnet asm.
2	-	1	Thread trimmer electromagnet unit
3	-	1	Cushion
4	-	1	Nut SM1/4×40
5	-	1	Pin
6	-	1	Thread trimmer electromagnet bracket
7	4802	2	Nut M4
8	201252	2	Spring washer M4
9	404420011	1	Screw SM15/64×28 L=8
10	302010012	1	Cushion
11	301010039	1	Washer $\phi 8 \times \phi 15.5 \times 0.8$
12	302010017	1	Trimming shaft
13	YP288	1	E-ring
14	302010055	1	Trimming cam crank asm.
15	302010616	1	Screw SM1/4×40 L=6
16	306010080	1	Spring
17	306010078	1	Spring cover
18	306010079	1	Thread trimmer cam
19	404440011	2	Screw SM1/4×40 L=10
20	302010019	1	Round knife bracket
21	302010059	1	Round knife
	302020059	1	Round knife H
22	404460004	2	Screw SM11/64×40 L=5.5
23	404510005	1	Nut SM11/64×40
24	302010021	1	Partiality shank
25	404420012	2	Screw SM11/64×40 L=12
26	302010020	1	Link
27	404410008	2	Axial screw
28	302010018	1	Trimming crank shaft
29	302010080	1	Shaft sleeve
30	301010002	1	Sleeve
31	306010022	1	Spring
	308010061	1	Spring H
32	302010013	1	Trimming crank
33	404430025	1	Screw SM3/16×28 L=14
34	302010022	1	Spacer
35	404440006	1	Screw SM15/64×28 L=10.5
36	302010015	1	Fixed knife
37	404460005	1	Screw SM9/64×40 L=6
38	201185	2	Washer $\phi 4.6 \times \phi 9.8 \times 0.8$
39	404440027	1	Screw SM9/64×40 L=9
40	404450033	1	Screw SM9/64×40 L=5
41	301010031	1	Washer $\phi 3.7 \times \phi 8 \times 0.8$
42	302010016	1	Dispart

11. D2 Component

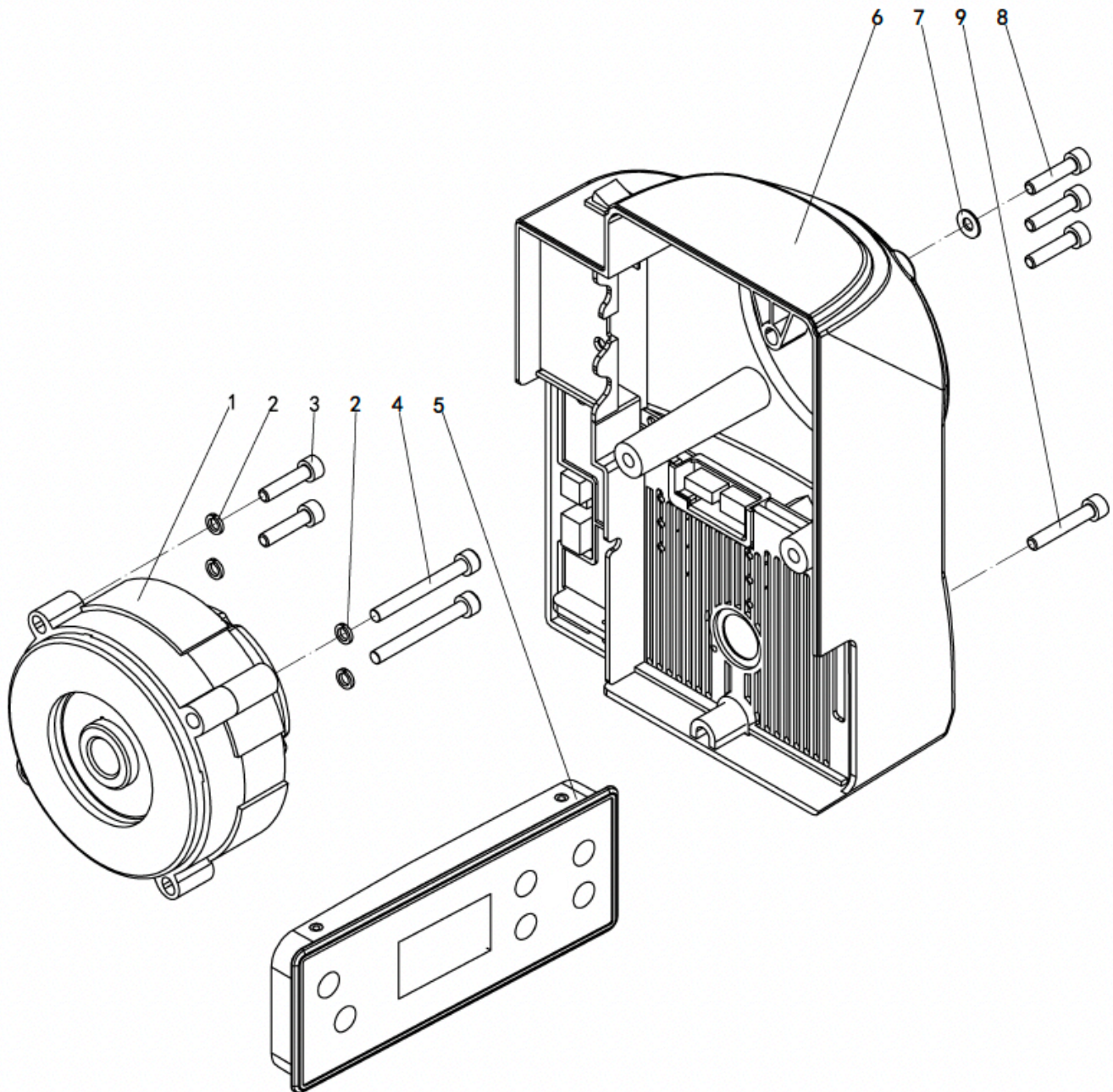

11. D2 Component

No.	Part No.	Qty.	Description
1	401010093	1	Motor
2	303067	4	Spring washer M5
3	404430032	2	Screw M5 L=25
4	404430038	2	Screw M5 L=45
5	312020008	1	Display operation panel component
6	312020009	1	Electronic control box asm.
7	404210011	1	Washer $\varnothing 6.7 \times \varnothing 19 \times 1$
8	404430023	3	Screw M5 L=20
9	404430014	1	Screw M5 L=30

